



## INTERNATIONAL APPLICATION PUBLISHED UNDER THE PATENT COOPERATION TREATY (PCT)

<p>(51) International Patent Classification <sup>6</sup> : C07H 21/02, 21/04, C07K 1/00, C12K 1/00</p>	A1	<p>(11) International Publication Number: <b>WO 00/23459</b> (43) International Publication Date: 27 April 2000 (27.04.00)</p>
<p>(21) International Application Number: PCT/US99/22955 (22) International Filing Date: 13 October 1999 (13.10.99)</p> <p>(30) Priority Data: 60/104,585 16 October 1998 (16.10.98) US 60/107,466 6 November 1998 (06.11.98) US 60/149,010 13 August 1999 (13.08.99) US</p> <p>(71) Applicant (for all designated States except US): IMMUNEX CORPORATION [US/US]; 51 University Street, Seattle, WA 98101 (US).</p> <p>(72) Inventors; and (75) Inventors/Applicants (for US only): MALISZEWSKI, Charles, R. [US/US]; 1014 Northwest 120th, Seattle, WA 98177 (US). GAYLE, Richard, B., III [US/US]; 17833 149th Avenue Northeast, Woodinville, WA 98072 (US). PRICE, Virginia, L. [US/US]; 2617 Boyer Avenue East, Seattle, WA 98102 (US). GIMPEL, Steven, D. [US/US]; 6842-26th Avenue Northeast, Seattle, WA 98115 (US).</p> <p>(74) Agent: SMITH, Julie, K.; Immunex Corporation, Law Dept., 51 University Street, Seattle, WA 98101 (US).</p>	<p>(81) Designated States: AE, AL, AM, AT, AU, AZ, BA, BB, BG, BR, BY, CA, CH, CN, CR, CU, CZ, DE, DK, DM, EE, ES, FI, GB, GE, GH, GM, HR, HU, ID, IL, IS, JP, KE, KG, KP, KR, KZ, LC, LK, LR, LS, LT, LU, LV, MA, MD, MG, MK, MN, MW, MX, NO, NZ, PL, PT, RO, RU, SD, SE, SG, SI, SK, SL, TJ, TM, TR, TT, TZ, UA, UG, US, UZ, VN, YU, ZA, ZW, ARIPO patent (GH, GM, KE, LS, MW, SD, SL, SZ, TZ, UG, ZW), Eurasian patent (AM, AZ, BY, KG, KZ, MD, RU, TJ, TM), European patent (AT, BE, CH, CY, DE, DK, ES, FI, FR, GB, GR, IE, IT, LU, MC, NL, PT, SE), OAPI patent (BF, BJ, CF, CG, CI, CM, GA, GN, GW, ML, MR, NE, SN, TD, TG).</p> <p>Published With international search report.</p>	
<p>(54) Title: INHIBITORS OF PLATELET ACTIVATION AND RECRUITMENT</p>		
<p>(57) Abstract</p> <p>The present invention provides soluble CD39 polypeptides and compositions, and methods for inhibiting platelet activation and recruitment in a mammal comprising administering a soluble CD39 polypeptide.</p>		

**FOR THE PURPOSES OF INFORMATION ONLY**

Codes used to identify States party to the PCT on the front pages of pamphlets publishing international applications under the PCT.

AL	Albania	ES	Spain	LS	Lesotho	SI	Slovenia
AM	Armenia	FI	Finland	LT	Lithuania	SK	Slovakia
AT	Austria	FR	France	LU	Luxembourg	SN	Senegal
AU	Australia	GA	Gabon	LV	Latvia	SZ	Swaziland
AZ	Azerbaijan	GB	United Kingdom	MC	Monaco	TD	Chad
BA	Bosnia and Herzegovina	GE	Georgia	MD	Republic of Moldova	TG	Togo
BB	Barbados	GH	Ghana	MG	Madagascar	TJ	Tajikistan
BE	Belgium	GN	Guinea	MK	The former Yugoslav Republic of Macedonia	TM	Turkmenistan
BF	Burkina Faso	GR	Greece	ML	Mali	TR	Turkey
BG	Bulgaria	HU	Hungary	MN	Mongolia	TT	Trinidad and Tobago
BJ	Benin	IE	Ireland	MR	Mauritania	UA	Ukraine
BR	Brazil	IL	Israel	MW	Malawi	UG	Uganda
BY	Belarus	IS	Iceland	MX	Mexico	US	United States of America
CA	Canada	IT	Italy	NE	Niger	UZ	Uzbekistan
CF	Central African Republic	JP	Japan	NL	Netherlands	VN	Viet Nam
CG	Congo	KE	Kenya	NO	Norway	YU	Yugoslavia
CH	Switzerland	KG	Kyrgyzstan	NZ	New Zealand	ZW	Zimbabwe
CI	Côte d'Ivoire	KP	Democratic People's Republic of Korea	PL	Poland		
CM	Cameroon	KR	Republic of Korea	PT	Portugal		
CN	China	KZ	Kazakhstan	RO	Romania		
CU	Cuba	LC	Saint Lucia	RU	Russian Federation		
CZ	Czech Republic	LI	Liechtenstein	SD	Sudan		
DE	Germany	LK	Sri Lanka	SE	Sweden		
DK	Denmark	LR	Liberia	SG	Singapore		
EE	Estonia						

TITLE

## INHIBITORS OF PLATELET ACTIVATION AND RECRUITMENT

REFERENCE TO RELATED APPLICATIONS

5 The present application is related to U.S. Provisional Application Serial Nos. 60/104,585, filed 16 October 1998, 60/107,466, filed 06 November 1998, and 60/149,010, filed 13 August 1999.

FIELD OF THE INVENTION

10 This invention relates to soluble CD39 compounds and compositions, the preparation thereof, and the use thereof to inhibit platelet activation and recruitment in a mammal.

BACKGROUND OF THE INVENTION

CD39 is a cell-surface antigen that was originally identified as a marker for mature B cells, but is also expressed on less mature B cells, Epstein-Barr Virus-transformed B cells, activated T cells, endothelial cells and some myeloid cell lines (Dörken et al., in *Leukocyte Typing IV*; W. Knapp, B. Dörken, and W.R. Gilks, Eds; Oxford University Press, New York, NY; pp. 89-90, 1989). Monoclonal antibodies against CD39 induce B cell homotypic adhesion, an activity that may be important in the regulation of immune function (Kansas and Tedder, *J. Immunol.* 147:4094-4102, 1991). Molecular cloning and characterization of CD39 indicated that it is unique cell surface molecule that contains two potential transmembrane regions and a hydrophobic segment within the putative extracellular domain (Maliszewski et al., *J. Immunol.* 153:3574, 1994). The amino acid sequence of CD39 was reported to exhibit some homology with a guanosine diphosphatase from yeast (Maliszewski et al., *supra*).

25 In 1996, an ATP diphosphohydrolase was cloned from potato tubers (Handa and Guidotti, *Biochem. Biophys. Res. Commun.* 218:916, 1996). The amino acid sequences of this and several other NTPases demonstrated a high degree of similarity, particularly within several small "apyrase conserved regions" (ACR). CD39 shares these conserved regions with soluble ATP-diphosphorylase from potato tubers, other apyrases and related enzymes. It was subsequently reported that native and recombinant full-length CD39 possess E-type ATP diphosphohydrolase (ATPDase) activity (Marcus et al., *J. Clin. Invest.* 99:1351, 1997); Kaczmarek et al., *J. Biol. Chem.* 271:33116, 1996); Wang and Guidotti, *J. Biol. Chem.* 271:9898, 1996). ATPDases degrade nucleoside tri- and/or diphosphates, but not monophosphates (Plesner, *Int. Rev. Cytol.* 158:141, 1995).

35 Vascular endothelial cells constitutively express a cell-surface ADPase (ecto-ATP diphosphohydrolase, apyrase, EC 3.6.1.5), one of at least 3 thromboregulatory systems which function in the maintenance of blood fluidity (Marcus and Safier, *FASEB J.* 7:516, 1983; Marcus et al., *J. Clin. Invest.* 88:1690, 1991). This ecto-ADPase, which belongs to the E-type ATPDase family, rapidly metabolizes ADP in the platelet releasate, terminating further platelet recruitment and aggregation.

Immunoprecipitation of HUVEC detergent lysates with anti-CD39 mAb resulted in complete capture of cell-associated ADPase activity, suggesting that CD39 is the only ecto-ADPase on endothelial cells (Marcus et al., *J. Clin. Invest.* 99:1351, 1997). In the same study, COS cell transfectants expressing recombinant CD39 at the cell surface totally inhibited ADP-induced platelet aggregation. Thus, CD39 plays a prominent role in thromboregulation (*see also*, Gayle et al., *J. Clin. Invest.*, 101:1851, 1998).

Excessive platelet activation (i.e., stimulation by an agonist) and recruitment, leading to platelet aggregation and vessel occlusion at sites of vascular injury in the coronary, carotid, and peripheral arteries, presents a major therapeutic challenge in cardiovascular medicine. Excessive platelet activation and recruitment is a contributing factor in clinical disorders including stroke, unstable angina, myocardial infarction, and restenosis following percutaneous coronary intervention including angioplasty, atherectomy, stent placement, and bypass surgery.

Glycoprotein IIb/IIIa antagonists, such as the monoclonal antibody marketed as ReoPro® (Centocor Inc.), are presently under development for the inhibition of platelet aggregation in patients undergoing percutaneous coronary intervention, and in patients with acute coronary syndromes such as unstable angina and myocardial infarction. The activation of glycoprotein IIb/IIIa receptors, however, is a late event in the cascade that leads to platelet aggregation.

There is a great need to identify additional therapeutic strategies and compositions for the pharmacological neutralization of platelet reactivity (activation, recruitment, aggregation). In particular, there is a need to identify compounds and compositions which target early portions of coagulation pathways such as the ADP-dependent activation and recruitment of platelets. There is, in fact, an urgent need to identify new strategies and compositions for the treatment of stroke, which is the third leading cause of death in the United States. In the case of stroke, an advantageous therapeutic agent will reduce intravascular thrombus burden and accompanying neurological defects without increasing intracerebral hemorrhage.

#### SUMMARY OF THE INVENTION

Soluble forms of CD39 having apyrase activity constitute a novel approach to the prevention and/or treatment of disease. The present invention provides soluble CD39 polypeptides and nucleic acids, compositions comprising a pharmaceutically acceptable carrier and a soluble CD39 polypeptide, and methods of making and using soluble CD39 polypeptides having apyrase activity. The effectiveness of soluble CD39 polypeptides have been demonstrated in vitro, ex vivo, and in vivo.

The invention is directed to soluble CD39 polypeptides selected from the group consisting of: (a) polypeptides having an amino acid sequence as set forth in Figure 1 (SEQ ID NO:2) wherein the amino terminus is selected from the group consisting of amino acids 36-44, and the carboxy terminus is selected from the group consisting of amino acids 471-478; (b) fragments of the polypeptides of (a) wherein said fragments have apyrase activity; (c) variants of the polypeptides of (a) or (b), wherein said variants have apyrase activity; and (d) fusion polypeptides comprising the polypeptides of (a), (b),

or (c), wherein said fusion polypeptides have apyrase activity. The invention provides compositions comprising a pharmaceutically acceptable carrier and a soluble CD39 polypeptide.

The invention is also directed to nucleic acids encoding a soluble CD39 polypeptide. The invention provides DNAs, vectors, recombinant cells, and recombinant methods for the production of soluble CD39 polypeptides.

The invention is further directed to the use of soluble CD39 polypeptides for inhibiting platelet activation and recruitment, for inhibiting angiogenesis, or for degrading nucleoside tri- and/or di- phosphates in a mammal in need of such treatment. The invention encompasses the use of a soluble CD39 polypeptide for the preparation of a medicament for inhibiting platelet activation and platelet recruitment, for inhibiting angiogenesis, or for degrading nucleoside tri- and/or di- phosphates in a mammal in need of such treatment. These and other aspects of the present invention will become evident upon reference to the following drawings, examples, and detailed description.

### BRIEF DESCRIPTION OF THE DRAWINGS

Figure 1 shows the predicted amino acid sequence (SEQ ID NO:2) of human CD39. The predicted amino acid sequence contains 6 potential N-linked glycosylation sites (double underline), and 11 cysteine residues (bold face). The two predicted transmembrane regions are underlined (single underline).

Figure 2 shows the domain structure of full length CD39 and of an engineered soluble form of CD39. The locations of transmembrane regions near the amino- and carboxy-termini, the centrally located hydrophobic sequence, and a section containing the four putative apyrase conserved regions (ACR) are indicated. Cysteine residues are marked as "C". The soluble CD39 contains a FLAG<sup>®</sup> peptide and new leader sequence and lacks the two transmembrane regions.

Figure 3 shows the immunoaffinity depletion of solCD39 from COS-1 conditioned medium (CM) following one (1X) or two (2X) rounds of adsorption. Samples were assayed for ATPase activity as described in Example 7. Data are expressed as pmoles of ATP degraded per minute.

Figure 4 shows the immunoprecipitation of solCD39 from COS-1 CM. Lane 2 shows the material that specifically bound to the antibody-coated beads. Lane 1 shows material that was pre-incubated with ovalbumin-coated beads to remove non-specifically bound material prior to addition of Ab-coated beads. Migration of molecular weight standards is indicated in kilodaltons (kDa).

Figure 5 shows the immunoaffinity purification and characterization of soluble CD39 (solCD39). Figure 5A shows fractions from the immunoaffinity column analyzed by SDS-PAGE, Figure 5B shows enzyme activity in the fractions, and Figure 5C shows purified solCD39 before (Lane 1) and after (Lane 2) treatment with N-glycanase.

Figure 6A shows pH optimum profiles of HUVEC membrane ecto-ADPase (●) and recombinant solCD39 (■). Figure 6B shows is an Eadie-Hofstee plot of rates of metabolism at different concentrations of ATP (●) or ADP (■) using purified solCD39 (6.5 ng).

Figure 7 shows inhibition of ADP-induced platelet reactivity by purified solCD39 in platelet-rich plasma from a donor who had ingested aspirin. The response to increasing concentrations of ADP is shown in Fig. 7A. The effect of increasing quantities of purified solCD39 on the platelet aggregation response to 10  $\mu$ M ADP is shown in Fig. 7B. Arrows indicate the addition of agonist.

5 Data are presented as relative light transmission vs. time (4 min duration).

Figure 8 shows a comparison of platelet reactivity as modulated by different agonists and inhibitors. The effects of CM from cells expressing solCD39 on platelet aggregation induced by 5  $\mu$ M ADP (Fig. 8A) and collagen (Fig. 8B) were compared in PRP and PRP treated with 10  $\mu$ M indomethacin. In Fig. 8B, 1  $\mu$ g/ml collagen was used in the upper samples and 3.3  $\mu$ g/ml in the lower (indomethacin-treated) samples. Fig. 8C shows the inhibition of collagen-induced aggregation by

10 (increasing quantities of solCD39 in PRP from a donor who had ingested aspirin. The arrows indicate the addition of agonist. Data are presented as relative light transmission vs time (4 min.).

Figure 9 shows the effect of FSBA-treated solCD39 on platelet reactivity. Fig. 9A shows the effects of purified solCD39, FSBA-treated solCD39, and mock-treated solCD39 (each at 4.4  $\mu$ g/ml)

15 on ASA-treated PRP after addition of 10  $\mu$ M ADP. Fig. 9B shows the effects of FSBA-treated solCD39 and mock-treated solCD39 (each at 22  $\mu$ g/ml) on ASA-treated PRP following addition of 3.3  $\mu$ g/ml collagen. Fig. 9C shows the titration of mock-treated solCD39 (0.88-2.2  $\mu$ g/ml) against FSBA-treated solCD39 (22  $\mu$ g/ml). ASA-treated PRP was stimulated with 10  $\mu$ M ADP. Arrows indicate addition of agonist. Data are presented as relative light transmission vs time.

Figure 10 shows pharmacokinetic analyses of solCD39 in mice. CD39 in serum was measured in the radioactive phosphate release ATPase assay ( $\blacksquare$ ) or the ADPase assay ( $\bullet$ ). Activities are expressed as pmoles nucleotide degraded per minute. The dashed line indicates the ATPase activity of 25  $\mu$ g/ml of solCD39 in murine serum. Distribution ( $t_{1/2\alpha} = 59$  min (ATP); 43 min (ADP)) and clearance ( $t_{1/2\beta} = 40$  h (ATP & ADP)) half-lives were determined using a biphasic curve fit.

20

Figure 11 shows bleeding times at 0 and 60 minutes in pigs treated with low, medium, or high doses of solCD39.

25

Figure 12 shows the effect of aspirin on pig platelet aggregation at baseline and day 5 after intravenous administration (Fig. 12A) and the effect of effect of high dose solCD39 on platelet aggregation at baseline and day 7 (Fig. 12B).

Figure 13 shows the inhibition of pig platelet aggregation by low, medium, and high doses of solCD39 as a function of time after bolus administration.

30

Figure 14 shows the concentration of CD39 in pig serum as a function of time after low, medium, or high dose administration. Distribution ( $t_{1/2\alpha} = 29$  min) and clearance ( $t_{1/2\beta} = 51$  h) half-lives were determined using a biphasic curve fit.

Figure 15 shows the ex vivo aggregation of murine platelets. Platelets were stimulated with 10  $\mu$ M ADP (Fig. 15A), 2.5  $\mu$ g/ml collagen (Fig. 15B), or 0.1 mM sodium arachidonate (Fig. 15C) after the administration of vehicle (saline), soluble CD39 (4 mg/kg) or aspirin (5 mg/kg). Soluble

35

CD39 treatment produced aggregation curves that returned to baseline following stimulation with agonists, but aspirin treatment yielded such a pattern only when arachidonate was the agonist.

Figure 16 shows reversal of the ADP-induced aggregation response in murine platelets when solCD39 is added at the peak of the aggregation response.

5 Figure 17 shows the inhibition of platelet (n=20, Fig. 17A) and fibrin (n=3, Fig. 17B) deposition following induction of stroke in mice pretreated with 8 mg/kg soluble CD39. "Fibrin" is a positive control, "Ipsilat" is ipsilateral (i.e., the ischemic hemisphere), and "Contralat" is the nonischemic hemisphere.

10 Figure 18 shows the comparative effects of vehicle (n=23), soluble CD39 (n=67) and aspirin (n=27) on the outcome of induced stroke in mice. Fig. 18A shows cerebral blood flow, 18B shows cerebral infarct volume, 18C shows neurological score (where higher scores indicate a worse deficit (Connolly, E.S., Jr., et al., Neurosurg. 38(3):523-532 (1996)), 18D shows mortality, and 18E shows intracerebral hemorrhage. \*p<0.05, †p<0.01, ‡p<0.001.

15 Figure 19 shows a covariate plot of cerebral infarct volume vs. intracerebral hemorrhage. Vehicle (saline), aspirin (ASA, 5 mg/kg prior to stroke), soluble CD39 (4 & 8 mg/kg, prior to stroke), and soluble CD39 (8 mg/kg, 3 h following stroke induction in mice) are compared.

Figure 20A shows the construct used to generate CD39<sup>-/-</sup> mice by homologous recombination. The labeled restriction sites are *Bgl*III (B), *Spe*I (S), and *Asp*718 (A). Figure 20B shows a genomic Southern blot as used to identify ES clones having a disrupted CD39 allele.

20 Figure 21 shows the bleeding times in control (n=15), aspirin-treated (5 mg/kg, n=10), solCD39-treated (4, 8, and 20 mg/kg, n=25) and solCD39<sup>-/-</sup> mice (n=10). (\*p<0.05, †p<0.01, ‡p<0.001).

25 Figure 22 shows a comparison of stroke outcomes in control (C57BL/6J x 129/J F1) mice (n=6), CD39<sup>-/-</sup> mice (n=5), and CD39<sup>-/-</sup> mice which were "reconstituted" with solCD39 (n=6). Figure 22A shows cerebral blood flow, 22B shows cerebral infarct volume, 22C shows neurological score, 22D shows mortality, and 22E shows intracerebral hemorrhage. \*p<0.05, †p<0.01, ‡p<0.001.

Figure 23 is a Kaplan-Meier plot showing that solCD39 causes an improvement in survival in a stringent lung ischemia-reperfusion model.

30 Figure 24 shows an alignment of the N-terminal amino acid sequences of human CD39 and human CD39-L4.

#### DETAILED DESCRIPTION OF THE INVENTION

A cDNA encoding the cell-surface molecule CD39 has been isolated, cloned and sequenced. The nucleic acid sequence and predicted amino acid sequence of this cDNA are shown in SEQ ID NO:1 and SEQ ID NO:2. The present invention provides methods of using soluble forms of CD39, which were constructed by removing the amino- and carboxy-terminal transmembrane domains. Soluble CD39 retains the capacity of wildtype CD39 to metabolize ATP and ADP at physiologically relevant concentrations as well as the ability to block and reverse ADP-induced platelet activation and

recruitment, including platelet aggregation. The use of soluble forms of CD39 is advantageous because purification of the polypeptides from recombinant host cells is facilitated, and because soluble polypeptides are generally more suitable than membrane-bound forms for clinical administration. Because CD39 inhibits platelet activation and recruitment, and therefore platelet aggregation, the present invention provides methods and compositions for inhibiting formation of a thrombus at a site in a mammal at which platelets are inappropriately activated, methods for use in controlling platelet reactivity, thereby regulating the hemostatic and thrombotic processes, and methods of inhibiting and/or reversing platelet aggregation.

#### 10 A. Hemostasis

Hemostasis is defined as the arrest of bleeding from damaged blood vessels, and results from a sequence of physiologic and biochemical events. At least three interacting biological systems are involved in hemostasis: components of the blood vessels (such as the subendothelial matrix), platelets, and plasma proteins (Marcus, A.J.: Disorders of Hemostasis, Ratnoff and Forbes, eds., W.B. Saunders, Philadelphia, 1996; pages 79-137; Marcus, A.J.: Platelet Activation, in: Atherosclerosis and Coronary Artery Disease, vol.1, Fuster, Ross and Topol, eds., Lipincott-Raven, Philadelphia, 1996; pages 607-637). A defect or defects in one or more of these systems can result in hemorrhagic disorder; conversely, the inappropriate activation of hemostasis culminates in development of arterial or venous thrombosis.

20 When a blood vessel is injured, it contracts, exposing subendothelial matrix components such as collagen, von Willebrand factor, fibronectin, thrombospondin, laminin, and microfibrils. Platelets adhere to, and are activated by, these components; collagen is an especially effective agonist for platelet activation. At least four physiologic events are initiated by platelet-collagen contact: the platelets release biologically active compounds; they express P-selectin on their cell surface (where it mediates adhesion of neutrophils, monocytes and subsets of lymphocytes); the platelet eicosanoid pathway is activated (starting with the liberation of arachidonic acid which forms prostaglandin H<sub>2</sub>); and the platelets undergo a drastic change in shape, from smooth disks to spiny spheres.

The biologically active compounds released by platelets are numerous, and multi-functional. Included in this group of components are serotonin, ATP, ADP, calcium, adhesive proteins (fibrinogen, fibronectin, thrombospondin, vitronectin, von Willebrand factor), growth factors (platelet-derived growth factor, transforming growth factor- $\beta$ , platelet factor 4) and coagulation factors (factor V, high-molecular weight kininogen, factor XI, protein S and plasminogen activator inhibitor-I (PAI-I)). Some of these compounds play a role in the recruitment of additional platelets and/or other cells such as neutrophils and monocytes to the site of activation, whereas others are involved in feedback mechanisms to down-regulate excessive thrombus formation.

35 At least three separate endothelial thromboregulatory systems exist: the eicosanoids including the prostaglandins PGI<sub>1</sub> and PGD<sub>2</sub>; endothelium-dependent relaxing factor (EDRF/NO); and the ectonucleotidase ATP-diphosphohydrolase (ATPDase) which has both ADPase and ATPase activities.



While collagen and thrombin are the prime inducers of platelet secretion, ADP is the most important agonist of platelet aggregation present in the platelet releasate. Catabolism of ADP to AMP by the ecto-ADPase blocks further recruitment of additional platelets to the site, reverses the aggregation response and blocks subsequent thrombus response.

5 Ecto-nucleotidase activity is demonstrable in vitro in an aggregometry system in which EDRF/NO effects and PGI<sub>2</sub> production are blocked by hemoglobin and aspirin respectively (Marcus and Safier, *FASEB J* 7:516; 1993). In this system, loss of platelet stimulatory activity in the supernatant fluid correlates with ADP catabolism. An ADPase activity has been identified in the membrane fraction of human endothelial cells; enzyme activity detected by polyacrylamide gel  
10 electrophoresis indicated both ATPase and ADPase (Marcus et al., *Clin. Res.* 40:226A (abstract), 1992).

#### B. Utility of the Claimed Invention

15 Significant research efforts are directed to the discovery and characterization of platelet aggregation inhibitors because of the potential utility of such inhibitors in treating occlusive vascular disease. For example, WO 95/12412 discloses platelet-specific chimeric antibodies and methods of using the same in treating various thrombotic disorders. A prototype description of the efforts to develop this therapeutic agent and obtain approval for its use as a human therapeutic agent (generic name: abciximab, trade name: ReoPro®) was described by B.S. Collier in *Circulation* 92:2373 (1995).

20 CD39 is an ecto-ADPase (apyrase) located on the surface of endothelial cells. This enzyme is mainly responsible for the maintenance of blood fluidity, thus maintaining platelets in the baseline (resting) state. This is accomplished by metabolism of the major platelet agonist, adenosine diphosphate, to adenosine monophosphate, which is not an agonist. Because ADP is the most important agonist of platelet aggregation, and is present in platelet releasate, a substance which  
25 catabolizes ADP is useful in treating or preventing disease states that involve inappropriate aggregation of platelets.

Examples of the therapeutic uses of soluble CD39 and compositions thereof include the treatment of individuals who suffer from coronary artery disease or injury following myocardial infarction, atherosclerosis, arteriosclerosis, preeclampsia, embolism, platelet-associated ischemic  
30 disorders including lung ischemia, coronary ischemia, and cerebral ischemia, and for the prevention of reocclusion following thrombosis, thrombotic disorders including coronary artery thrombosis, cerebral artery thrombosis, intracardiac thrombosis, peripheral artery thrombosis, venous thrombosis, and thrombosis and coagulopathies associated with exposure to a foreign or injured tissue surface, in combination with angioplasty, carotid endarterectomy, anastomosis of vascular grafts, and chronic  
35 cardiovascular devices such as in-dwelling catheters or shunts. Other instances in which it would be useful to inhibit increased ADP release due to increased platelet stimulation would be in individuals at high risk for thrombus formation or reformation (severe arteriosclerosis), and inhibition of occlusion, reocclusion, stenosis and/or restenosis of blood vessels. Individuals who will benefit from therapies

that involve inhibiting ADP-induced aggregation of platelets include those at risk for advanced coronary artery disease, and those that are or will be undergoing angioplasty procedures (i.e., balloon angioplasty, laser angioplasty, coronary atherectomy and similar techniques). Inhibition of platelet aggregation will also be useful in individuals undergoing surgery that has a high risk of thrombus formation (i.e., coronary bypass surgery, insertion of a prosthetic valve or vessel and the like), and in the prevention or treatment of deep venous thrombosis (DVT), pulmonary embolism (PE), transient ischemic attacks (TIAs) and other related conditions where arterial occlusion is the common underlying feature. In addition, the ability of CD39 to block platelet activation and recruitment is useful for preventing stroke and for treating patients experiencing stroke due to vascular occlusion. In particular, the methods, compounds, and compositions of the present invention have the ability to inhibit microvascular thrombosis, improve postischemic cerebral blood flow, and reduce cerebral infarction volumes and neurological deficit without inducing intracerebral hemorrhage, in stroke. Soluble CD39 and compositions thereof according to the present invention can also be administered in any other therapeutic setting where it would be useful to degrade nucleoside tri- and/or diphosphates. As an example, soluble CD39 may be used as an anti-neoplastic agent to inhibit angiogenesis and/or prevent the survival benefits that ATP provides to tumor cells, or to treat other diseases or conditions mediated by angiogenesis such as ocular neovascularization.

Soluble CD39 polypeptides also have many non-therapeutic uses, since they may be used in any application where soluble ATPase and/or ADPase activity is advantageous. As an example, soluble CD39 polypeptides may be used in compositions for preserving platelets such as those described by Gepner-Puszkin (U.S. Patent No. 5,378,601). As another example, soluble CD39 polypeptides may be used in pyrophosphate-based DNA sequencing methodologies such as those described by Ronaghi et al. (*Science* 281:336, 1998). As a further example, soluble CD39 polypeptides can be used to screen for apyrase inhibitors.

### C. CD39 Polypeptides

The molecular cloning and structural characterization of CD39 is presented in Maliszewski et al. (*J. Immunol.* 153:3574, 1994). CD39 contains two putative transmembrane regions, near the amino and carboxy termini, which may serve to anchor the native protein in the cell membrane. The portion of the molecule between the transmembrane regions is external to the cell. As used herein, the term "CD39 polypeptides" includes CD39, homologs of CD39, variants, fragments, and derivatives of CD39, fusion polypeptides comprising CD39, and soluble forms of CD39 polypeptides.

Soluble polypeptides are polypeptides that are capable of being secreted from the cells in which they are expressed. A secreted soluble polypeptide may be identified (and distinguished from its non-soluble membrane-bound counterparts) by separating intact cells which express the desired polypeptide from the culture medium, e.g., by centrifugation, and assaying the medium (supernatant) for the presence of the desired polypeptide. The presence of the desired polypeptide in the medium

indicates that the polypeptide was secreted from the cells and thus is a soluble form of the polypeptide. The use of soluble forms of CD39 is advantageous for many applications. Purification of the polypeptides from recombinant host cells is facilitated, since the soluble polypeptides are secreted from the cells. Moreover, soluble polypeptides are generally more suitable than membrane-bound forms for parenteral administration and for many enzymatic procedures.

5 Apyrase activity resides in the extracellular domain of CD39. Thus, for applications requiring biological activity, useful CD39 polypeptides include soluble forms of CD39 such as those having an amino terminus selected from the group consisting of amino acids 36-44 of SEQ ID NO:2, and a carboxy terminus selected from the group consisting of amino acids 471-478 of SEQ ID NO:2, and which exhibit CD39 biological activity. Soluble CD39 polypeptides also include those polypeptides which include part of either or both of the transmembrane regions, provided that the soluble CD39 polypeptide is capable of being secreted from a cell, and retains CD39 biological activity. Soluble CD39 polypeptides further include oligomers or fusion polypeptides comprising the extracellular portion of CD39, and fragments of any of these polypeptides that have biological activity.

15 The term "biological activity," as used herein, includes apyrase enzymatic activity as well as the ex vivo and in vivo activities of CD39. Apyrases catalyze the hydrolysis of nucleoside tri- and/or di-phosphates, but a given apyrase may display different relative specificities for either nucleoside triphosphates or nucleoside diphosphates. Biological activity of soluble forms of CD39 may be determined, for example, in an ectonucleotidase or apyrase assay (e.g. ATPase or ADPase assays), or in an assay that measures inhibition of platelet aggregation. Exemplary assays are disclosed herein; those of skill in the art will appreciate that other, similar types of assays can be used to measure biological activity.

20 Among the soluble CD39 polypeptides provided herein are variants (also referred to as analogs) of native CD39 polypeptides that retain a biological activity of CD39. Such variants include polypeptides that are substantially homologous to native CD39, but which have an amino acid sequence different from that of a native CD39 because of one or more deletions, insertions or substitutions. Particular embodiments include, but are not limited to, CD39 polypeptides that comprise from one to ten deletions, insertions or substitutions of amino acid residues, when compared to a native CD39 sequence. The CD39-encoding DNAs of the present invention include variants that differ from a native CD39 DNA sequence because of one or more deletions, insertions or substitutions, but that encode a biologically active polypeptide. Included as variants of CD39 polypeptides are those variants that are naturally occurring, such as allelic forms and alternatively spliced forms, as well as variants that have been constructed by modifying the amino acid sequence of a CD39 polypeptide or the nucleotide sequence of a nucleic acid encoding a CD39 polypeptide.

35 Generally, substitutions for one or more amino acids present in the native polypeptide should be made conservatively. Examples of conservative substitutions include substitution of amino acids outside of the active domain(s), and substitution of amino acids that do not alter the secondary and/or tertiary structure of CD39. Additional examples include substituting one aliphatic residue for another,

such as Ile, Val, Leu, or Ala for one another, or substitutions of one polar residue for another, such as between Lys and Arg; Glu and Asp; or Gln and Asn. Other such conservative substitutions, for example, substitutions of entire regions having similar hydrophobicity characteristics, are known in the art.

- 5           When a deletion or insertion strategy is adopted, the potential effect of the deletion or insertion on biological activity must be considered. Subunits of the inventive polypeptides may be constructed by deleting terminal or internal residues or sequences. Additional guidance as to the types of mutations that can be made is provided by a comparison of the sequence of CD39 to polypeptides that have similar structures, as well as by performing structural analysis of the inventive polypeptides.
- 10           The native sequence of full length CD39 is set forth in Figure 1 (SEQ ID NO:2). In some preferred embodiments the CD39 variants are at least about 70% identical in amino acid sequence to the amino acid sequence of native CD39 as set forth in the sequence listing; in some preferred
- 15           embodiments the CD39 variants are at least about 80% identical in amino acid sequence to the amino acid sequence of native CD39 as set forth in the sequence listing. In some more preferred
- 20           embodiments the variants of CD39 are at least about 90% identical in amino acid sequence to the amino acid sequence of native CD39 as set forth in the sequence listing; in some more preferred
- 25           embodiments the variants of CD39 are at least about 95% identical in amino acid sequence to the amino acid sequence of native CD39 as set forth in the sequence listing. In some most preferred
- 30           embodiments, variants of CD39 are at least about 98% identical in amino acid sequence to the amino acid sequence of native CD39 as set forth in the sequence listing; in some most preferred
- 35           embodiments, variants of CD39 are at least about 99% identical in amino acid sequence to the amino acid sequence of native CD39 as set forth in the sequence listing. Percent identity, in the case of both polypeptides and nucleic acids, may be determined by visual inspection. Percent identity may be determined using the alignment method of Needleman and Wunsch (*J. Mol. Biol.* 48:443, 1970) as revised by Smith and Waterman (*Adv. Appl. Math* 2:482, 1981). Preferably, percent identity is determined by using a computer program, for example, the GAP computer program version 10.x available from the Genetics Computer Group (GCG; Madison, WI, see also Devereux et al., *Nucl. Acids Res.* 12:387, 1984). The preferred default parameters for the GAP program include: (1) a unary comparison matrix (containing a value of 1 for identities and 0 for non-identities) for nucleotides, and the weighted comparison matrix of Gribskov and Burgess, *Nucl. Acids Res.* 14:6745, 1986, as described by Schwartz and Dayhoff, eds., *Atlas of Protein Sequence and Structure*, National Biomedical Research Foundation, pp. 353-358, 1979 for amino acids; (2) a penalty of 30 (amino acids) or 50 (nucleotides) for each gap and an additional 1 (amino acids) or 3 (nucleotides) penalty for each symbol in each gap; (3) no penalty for end gaps; and (4) no maximum penalty for long gaps.
- Other programs used by one skilled in the art of sequence comparison may also be used. For fragments of CD39, the percent identity is calculated based on that portion of CD39 that is present in the fragment.

The primary amino acid structure of soluble CD39 may be modified to create CD39 derivatives by forming covalent or aggregative conjugates with other chemical moieties, such as glycosyl groups, lipids, phosphate, acetyl groups and the like. Covalent derivatives of CD39 are prepared by linking particular functional groups to CD39 amino acid side chains or at the N-terminus or C-terminus of a CD39 polypeptide or the extracellular domain thereof. CD39 derivatives also include CD39 polypeptides bound to various insoluble substrates, including cyanogen bromide-activated agarose structures, or similar agarose structures, or adsorbed to polyolefin surfaces (with or without glutaraldehyde cross-linking).

Fusion polypeptides of soluble CD39 within the scope of this invention include covalent or aggregative conjugates of CD39 or its fragments with other polypeptides, such as by synthesis in recombinant culture as N-terminal or C-terminal fusions. One class of fusion polypeptides are discussed below in connection with soluble CD39 oligomers. As another example, a fusion polypeptide may comprise a signal peptide (which is also variously referred to as a signal sequence, signal, leader peptide, leader sequence, or leader) at the N-terminal region or C-terminal region of a CD39 polypeptide which co-translationally or post-translationally directs transfer of the polypeptide from its site of synthesis to a site inside or outside of the cell membrane or cell wall (e.g. the  $\alpha$ -factor leader of *Saccharomyces*; several leader sequences are discussed in the examples that follow). It is particularly advantageous to fuse a signal peptide that promotes extracellular secretion to the N-terminus of a soluble CD39 polypeptide. In this case, the signal peptide is typically cleaved upon secretion of the soluble CD39 from the cell.

In a particularly preferred embodiment, one or more amino acids are added to the N-terminus of a soluble CD39 polypeptide in order to improve the expression levels and/or stability of the CD39 polypeptide. The one or more amino acids include an Ala residue, fragments derived from the N-terminus of another member of the CD39 family (e.g., CD39L2, CD39L3, CD39L4) or from another polypeptide such as IL-2, and other peptides, either naturally-occurring or designed based upon structural predictions, capable of adopting a stable secondary structure.

In a most preferred embodiment, a soluble CD39 polypeptide is initially synthesized as a fusion polypeptide comprising: (a) a signal peptide that promotes extracellular secretion of the soluble CD39 from the cell, the signal peptide being cleaved upon secretion, (b) one or more amino acids added to the N-terminus of the soluble CD39 polypeptide in order to improve expression levels and/or stability, and (c) a fragment of CD39 that possesses biological activity.

CD39 fusion polypeptides can also comprise polypeptides added to provide novel polyfunctional entities. Further, soluble CD39-containing fusion polypeptides can comprise peptides added to facilitate purification and identification of soluble CD39. Such peptides include, for example, poly-His or the antigenic identification peptides described in U.S. Patent No. 5,011,912 and in Hopp et al., *Bio/Technology* 6:1204, 1988. One such peptide is the FLAG<sup>®</sup> peptide, Asp-Tyr-Lys-Asp-Asp-Asp-Lys (SEQ ID NO:10), which is highly antigenic and provides an epitope reversibly

bound by a specific monoclonal antibody, enabling rapid assay and facile purification of expressed recombinant polypeptide. A murine hybridoma designated 4E11 produces a monoclonal antibody that binds the FLAG<sup>®</sup> peptide in the presence of certain divalent metal cations, as described in U.S. Patent 5,011,912, hereby incorporated by reference. The 4E11 hybridoma cell line has been deposited with  
5 the American Type Culture Collection under accession no. HB 9259. Monoclonal antibodies that bind the FLAG<sup>®</sup> peptide are available from Eastman Kodak Co., Scientific Imaging Systems Division, New Haven, Connecticut.

Another particularly useful class of fusion polypeptides includes those that allow localization or concentration of CD39 at a site of platelet activation and recruitment. Such fusion polypeptides  
10 comprise a moiety that specifically binds activated platelets and CD39, and can be prepared using recombinant DNA technology, or by using standard techniques for conjugation of polypeptides. For example, WO 95/12412 discloses platelet-specific chimeric antibodies and methods of using the same in treating various thrombotic disorders. These antibodies, or other platelet specific antibodies (for example, antibodies to P-selectin/CD62), are useful in forming fusion polypeptides with CD39.  
15 Moreover, humanized or single chain antibodies can be prepared, based on such platelet specific antibodies.

Counterstructure molecules (molecules that specifically bind polypeptides expressed on the cell surface of activated platelets) and fragments thereof that bind to platelets are also useful in forming fusion polypeptides that bind specifically to activated platelets. Exemplary counterstructures  
20 include ligands for P-selectin/CD62 (see, i.e., Varki A., *Proc Natl Acad Sci U S A* 91:7390, 1994; Sammar et al., *Int Immunol* 6:1027, 1994; Lenter et al., *J Cell Biol* 125:471, 1994).

Encompassed by the present invention are oligomers that contain CD39 polypeptides. CD39 oligomers may be in the form of covalently-linked or non-covalently-linked multimers, including dimers, trimers, or higher oligomers. Oligomers may be linked by disulfide bonds formed between  
25 cysteine residues on different CD39 polypeptides. Alternatively, oligomers may be formed by constructing fusion polypeptides of CD39 and the Fc region of an immunoglobulin molecule, such as human IgG<sub>1</sub>, to yield a CD39/Fc fusion polypeptide. The term "Fc polypeptide" as used herein includes native and mutein forms of polypeptides derived from the Fc region of an antibody. Truncated forms of such polypeptides containing the hinge region that promotes dimerization are also  
30 included. One suitable Fc polypeptide, described in PCT application WO 93/10151 (hereby incorporated by reference), is a single chain polypeptide extending from the N-terminal hinge region to the native C-terminus of the Fc region of a human IgG<sub>1</sub> antibody. Another useful Fc polypeptide is the Fc mutein described in U.S. Patent 5,457,035 and in Baum et al., (*EMBO J.* 13:3992-4001, 1994). The amino acid sequence of this mutein is identical to that of the native Fc sequence presented in WO  
35 93/10151, except that amino acid 19 has been changed from Leu to Ala, amino acid 20 has been changed from Leu to Glu, and amino acid 22 has been changed from Gly to Ala. The mutein exhibits reduced affinity for Fc receptors. The CD39/Fc fusion polypeptides are allowed to assemble much

like heavy chains of an antibody molecule to form divalent CD39. If fusion polypeptides are made with both heavy and light chains of an antibody, it is possible to form a CD39 oligomer with as many as four CD39 extracellular regions.

5 In some embodiments of the invention, oligomers comprising multiple CD39 polypeptides are joined via covalent or non-covalent interactions between peptide moieties fused to the C39-polypeptides. Such peptide moieties may be peptide linkers (spacers), or peptides that have the property of promoting oligomerization. Leucine zippers and certain polypeptides derived from antibodies are among the peptides that can promote oligomerization of polypeptides.

10 The present invention comprises fusion polypeptides with or without spacer amino acid linking groups. For example, two soluble CD39 domains can be linked with a linker sequence, such as (Gly)<sub>4</sub>Ser(Gly)<sub>5</sub>Ser, which is described in United States Patent 5,073,627. Other linker sequences include, for example, GlyAlaGlyGlyAlaGlySer(Gly)<sub>5</sub>Ser, (Gly<sub>4</sub>Ser)<sub>2</sub>, (GlyThrPro)<sub>3</sub>, and (Gly<sub>4</sub>Ser)<sub>3</sub>Gly<sub>4</sub>SerGly<sub>5</sub>Ser. Alternatively, CD39 can be linked to another polypeptide (non-CD39) with or without a spacer amino acid linking group. As shown in Example 9, ThrSerSer or  
15 ThrSerSerGly linkers may be used to fuse IL2 residues to soluble CD39. For the expression of soluble CD39, the inventors have made the surprising and unexpected discovery, that the fusion of 12 amino acids from the N-terminus of mature human IL2 to the solCD39 coding region, results in high levels of both expression and activity in the supernatants of transfected cells. Among the particularly preferred embodiments of the invention, therefore, are soluble CD39 polypeptides having an amino acid  
20 sequence SEQ ID NO:6 and nucleic acids, such as SEQ ID NO:5, that encode soluble CD39 polypeptides having an amino acid sequence SEQ ID NO:6.

The present invention further includes soluble CD39 polypeptides with or without associated native-pattern glycosylation. CD39 expressed in yeast or mammalian expression systems (e.g., COS-7 cells) may be similar to or significantly different from a native CD39 polypeptide in molecular weight  
25 and glycosylation pattern, depending upon the choice of expression system. Expression of CD39 polypeptides in bacterial expression systems, such as *E. coli*, provides non-glycosylated molecules.

Different host cells may process polypeptides differentially, resulting in heterogeneous mixtures of polypeptides with variable N- or C-termini. Expression of soluble CD39 polypeptides in microbial expression systems, such as *E. coli*, generally provides a homogeneous polypeptide  
30 preparation. Polypeptides may be differentially processed by a eukaryotic cell, resulting in variable N- and C-termini, and hence yield a heterogeneous polypeptide preparation. The present invention includes polypeptides, produced by eukaryotic host cells, which have variable N-termini or C-termini. In one embodiment of the inventive CD39 polypeptides, the amino and carboxy termini can be about five amino acids different from those disclosed herein.

35 The skilled artisan will also recognize that the position(s) at which a signal peptide is cleaved may differ from that predicted by computer program, and may vary according to such factors as the type of host cells employed in expressing a recombinant soluble CD39 polypeptide. A polypeptide

preparation according to the invention may therefore include a mixture of polypeptide molecules having different N-terminal amino acids, resulting from cleavage of the signal peptide at more than one site.

#### D. Nucleic Acids

5           The invention encompasses full length nucleic acid molecules encoding soluble CD39 as well as isolated fragments and oligonucleotides derived from the nucleotide sequence of SEQ ID NO:1. Such nucleic acid sequences may include nucleotides 178-1494 of SEQ ID NO:1 or a fragment thereof, and DNA and/or RNA sequences that hybridize to the coding region of the nucleotide sequence of SEQ ID NO:1, or its complement, under conditions of moderate stringency, and which  
10        encode polypeptides or fragments thereof of the invention.

          Nucleic acid sequences encoding soluble CD39 polypeptides having altered glycosylation sites, deleted or substituted Cys residues, or modified proteolytic cleavage sites, nucleic acid sequences encoding sub-units of CD39 polypeptides or fusion polypeptides of CD39 with other peptides, allelic variants of CD39, mammalian homologs of CD39, and nucleic acid sequences  
15        encoding CD39 polypeptides derived from alternative mRNA constructs, or those that encode peptide having substituted or additional amino acids, are examples of nucleic acid sequences according to the invention.

          Due to degeneracy of the genetic code, there can be considerable variation in nucleotide sequences encoding the same amino acid sequence. Included as embodiments of the invention are  
20        sequences capable of hybridizing under moderately stringent conditions (e.g., prewashing solution of 5 X SSC, 0.5% SDS, 1.0 mM EDTA (pH 8.0) and hybridization conditions of 50°C, 5 X SSC, overnight) to the DNA sequences encoding soluble CD39, and other sequences which are degenerate to those which encode soluble CD39. The skilled artisan can determine additional combinations of salt and temperature that constitute moderate hybridization stringency. Conditions of higher  
25        stringency include higher temperatures for hybridization and post-hybridization washes, and/or lower salt concentration.

          In a preferred embodiment, CD39 DNAs include those that encode polypeptides that are at least about 70% or at least 80% identical in amino acid sequence to the amino acid sequence of native CD39 polypeptide as set forth in SEQ ID NO:1. In a more preferred embodiment, the encoded  
30        variants of CD39 are at least about 90% or at least about 95% identical in amino acid sequence to the native form of CD39; in a most preferred embodiment, the encoded variants of CD39 are at least about 98% or at least about 99% identical in amino acid sequence to the native form of CD39. For DNAs that encode a fragment of CD39, percent identity of the fragment is based on percent identity to the corresponding portion of full-length CD39.

35        Mutations can be introduced into nucleic acids by synthesizing oligonucleotides containing a mutant sequence, flanked by restriction sites enabling ligation to fragments of the native sequence.



Following ligation, the resulting reconstructed sequence encodes a variant having the desired amino acid insertion, substitution, or deletion.

Alternatively, oligonucleotide-directed site-specific mutagenesis procedures can be employed to provide an altered gene having particular codons altered according to the substitution, deletion, or insertion required. Exemplary methods of making the alterations set forth above are disclosed by Walder et al. (*Gene* 42:133, 1986); Bauer et al. (*Gene* 37:73, 1985); Craik (*BioTechniques*, January 1985, 12-19); Smith et al. (*Genetic Engineering: Principles and Methods*, Plenum Press, 1981); and U.S. Patent Nos. 4,518,584 and 4,737,462 disclose suitable techniques, and are incorporated by reference herein.

10 The well known polymerase chain reaction (PCR) procedure also may be employed to generate and amplify a DNA sequence encoding a desired polypeptide or fragment thereof. Oligonucleotides that define the desired termini of the DNA fragment are employed as 5' and 3' primers. The oligonucleotides may additionally contain recognition sites for restriction endonucleases to facilitate insertion of the amplified DNA fragment into an expression vector. PCR techniques are described in Saiki et al., *Science* 239:487, 1988; *Recombinant DNA Methodology*, Wu et al., eds., Academic Press, Inc., San Diego, 1989, pp. 189-196; and *PCR Protocols: A Guide to Methods and Applications*, Innis et al., eds., Academic Press, Inc., 1990.

DNA sequences that encode CD39 polypeptides comprising various additions or substitutions of amino acid residues or sequences, or deletions of terminal or internal residues or sequences not needed for biological activity can be prepared. For example, N-glycosylation sites can be modified to preclude glycosylation while allowing expression of a homogeneous, reduced carbohydrate variant using yeast expression systems. N-glycosylation sites in eukaryotic polypeptides are characterized by an amino acid triplet Asn-X-Y, wherein X is any amino acid except Pro and Y is Ser or Thr. Appropriate modifications to the nucleotide sequence encoding this triplet will result in substitutions, additions or deletions that prevent attachment of carbohydrate residues at the Asn side chain.

20 In another example, sequences encoding Cys residues can be altered to cause the Cys residues to be deleted or replaced with other amino acids, preventing formation of incorrect intramolecular disulfide bridges upon renaturation. Thus, Cys residues may be replaced with another amino acid or deleted without affecting polypeptide tertiary structure or disulfide bond formation.

30 Other approaches to mutagenesis involve modification of sequences encoding dibasic amino acid residues to enhance expression in yeast systems in which KEX2 protease activity is present. Other variants are prepared by modification of adjacent dibasic amino acid residues, to enhance expression in yeast systems in which KEX2 protease activity is present. EP 212,914 discloses the use of site-specific mutagenesis to inactivate KEX2 protease processing sites in a polypeptide. KEX2 protease processing sites are inactivated by deleting, adding or substituting residues to alter Arg-Arg, Arg-Lys, and Lys-Arg pairs to eliminate the occurrence of these adjacent basic residues. Similar modification may be made to sequences encoding sites recognized and cleaved by other proteolytic enzymes. Subunits of a CD39 polypeptide may be constructed by deleting sequences encoding terminal or internal

residues or sequences not necessary for biological activity. Sequences encoding fusion polypeptides as described below may be constructed by ligating sequences encoding additional amino acid residues to the inventive sequences without affecting biological activity.

5 Mutations in nucleotide sequences constructed for expression of a soluble CD39 must, of course, preserve the reading frame phase of the coding sequences and preferably will not create complementary regions that could hybridize to produce secondary mRNA structures such as loops or hairpins which would adversely affect translation of the receptor mRNA. Although a mutation site may be predetermined, it is not necessary that the nature of the mutation *per se* be predetermined. For example, in order to select for optimum characteristics of mutants at a given site, random mutagenesis  
10 may be conducted at the target codon and the expressed mutated polypeptides screened for the desired activity.

Not all mutations in the nucleotide sequence which encodes a CD39 polypeptide will be expressed in the final product, for example, nucleotide substitutions may be made to enhance expression, primarily to avoid secondary structure loops in the transcribed mRNA (see EPA 75,444A,  
15 incorporated herein by reference), or to provide codons that are more readily translated by the selected host, e.g., the well-known *E. coli* preference codons for *E. coli* expression.

In the genome, CD39 polypeptides are encoded by multi-exon genes. The present invention further includes alternative mRNA constructs which can be attributed to different mRNA splicing events following transcription and which hybridize with the cDNAs disclosed herein under conditions  
20 of moderate stringency. CD39 polypeptides according to the invention include allelic variations of the sequence shown in SEQ ID NO:1, and sequences encoding CD39 polypeptides that comprise additional amino acids to those of SEQ ID NO:1.

The isolated nucleic acid sequences of this invention are sufficiently free of association with nucleic acid sequences encoding other proteinaceous material, and from other materials found in living  
25 cells, such as proteins, lipids or carbohydrates, to allow the skilled artisan to prepare vectors for the expression of soluble CD39 polypeptides.

#### E. Recombinant Expression Systems

The present invention also provides recombinant cloning and expression vectors containing CD39 DNA, as well as host cells containing the recombinant vectors. Expression vectors comprising  
30 CD39 DNA may be used to prepare soluble CD39 polypeptides encoded by the DNA. The expression vectors carrying the recombinant CD39 DNA sequence are transferred, for example by transfection or transformation, into a substantially homogeneous culture of a suitable host microorganism or mammalian cell line. Transformed host cells are cells which have been transformed or transfected with nucleotide sequences encoding CD39 polypeptides and express CD39 polypeptides. Expressed  
35 CD39 polypeptides will be located within the host cell and/or secreted into culture supernatant fluid, depending upon the nature of the host cell and the gene construct inserted into the host cell. The

skilled artisan will recognize that the procedure for purifying the expressed CD39 will vary according to such factors as the type of host cells employed.

Any suitable expression system may be employed. Recombinant expression vectors for expression of soluble CD39 by recombinant DNA techniques include a CD39 DNA sequence  
5 comprising a synthetic or cDNA-derived DNA fragment encoding a CD39 polypeptide, operably linked to a suitable transcriptional or translational regulatory nucleotide sequence, such as one derived from a mammalian, microbial, viral, or insect gene.

Examples of regulatory sequences include transcriptional promoters, operators, or enhancers, an mRNA ribosomal binding site, and appropriate sequences which control transcription and  
10 translation initiation and termination. Nucleotide sequences are operably linked when the regulatory sequence functionally relates to the CD39 DNA sequence. Thus, a promoter nucleotide sequence is operably linked to a CD39 DNA sequence if the promoter nucleotide sequence controls the transcription of the CD39 DNA sequence. An origin of replication that confers the ability to replicate in the desired host cells, and a selection gene by which transformants are identified, are generally  
15 incorporated into the expression vector.

In addition, a sequence encoding an appropriate signal peptide (native or heterologous) can be incorporated into expression vectors. A DNA sequence for a signal peptide (secretory leader) may be fused in frame to the CD39 sequence so that the CD39 is initially translated as a fusion polypeptide comprising the signal peptide. A signal peptide that is functional in the intended host cells promotes  
20 extracellular secretion of the CD39 polypeptide. The signal peptide is cleaved from the CD39 polypeptide upon secretion of soluble CD39 from the cell.

Regarding signal peptides that may be employed in producing soluble CD39, the native signal peptide may be replaced by a heterologous signal peptide or leader sequence, if desired. The choice of signal peptide or leader may depend on factors such as the type of host cells in which the recombinant  
25 polypeptide is to be produced. To illustrate, examples of heterologous signal peptides that are functional in mammalian host cells include the signal sequence for interleukin-7 (IL-7) described in United States Patent 4,965,195, the signal sequence for interleukin-2 receptor described in Cosman et al., *Nature* 312:768, 1984; the interleukin-4 receptor signal peptide described in EP 367,566; the type I interleukin-1 receptor signal peptide described in U.S. Patent 4,968,607; and the type II interleukin-1  
30 receptor signal peptide described in EP 460,846. For the expression of soluble CD39, the inventors have made the surprising and unexpected discovery that the use of a leader containing sequences derived from a human IL-2 polypeptide (SEQ ID NO:9) results in high levels of ATPase activity in the supernatants of transfected cells. Among the particularly preferred embodiments of the invention, therefore, are nucleic acids encoding soluble CD39 polypeptides having an amino acid sequence SEQ  
35 ID NO:8.

Suitable host cells for expression of CD39 polypeptides include prokaryotes, yeast or higher eukaryotic cells. Mammalian or insect cells are generally preferred for use as host cells. Appropriate cloning and expression vectors for use with bacterial, fungal, yeast, and mammalian cellular hosts are

described, for example, in Pouwels et al. *Cloning Vectors: A Laboratory Manual*, Elsevier, New York, 1985. Cell-free translation systems could also be employed to produce soluble CD39 polypeptides using RNAs derived from DNA constructs disclosed herein.

5 Prokaryotes include gram negative or gram positive organisms, for example, *E. coli* or *Bacilli*. Suitable prokaryotic host cells for transformation include, for example, *E. coli*, *Bacillus subtilis*, *Salmonella typhimurium*, and various other species within the genera *Pseudomonas*, *Streptomyces*, and *Staphylococcus*. In a prokaryotic host cell, such as *E. coli*, polypeptides may include an N-terminal methionine residue to facilitate expression of the recombinant polypeptide in the prokaryotic host cell. The N-terminal Met may be cleaved from the expressed recombinant  
10 polypeptide.

Expression vectors for use in prokaryotic host cells generally comprise one or more phenotypic selectable marker genes. A phenotypic selectable marker gene is, for example, a gene encoding a protein that confers antibiotic resistance or that supplies an autotrophic requirement. Examples of useful expression vectors for prokaryotic host cells include those derived from  
15 commercially available plasmids such as the cloning vector pBR322 (ATCC 37017). pBR322 contains genes for ampicillin and tetracycline resistance and thus provides simple means for identifying transformed cells. An appropriate promoter and a CD39 DNA sequence are inserted into the pBR322 vector. Other commercially available vectors include, for example, pKK223-3 (Pharmacia Fine Chemicals, Uppsala, Sweden) and pGEM1 (Promega Biotec, Madison, WI, USA).

20 Promoter sequences commonly used for recombinant prokaryotic host cell expression vectors include  $\beta$ -lactamase (penicillinase), lactose promoter system (Chang et al., *Nature* 275:615, 1978; and Goeddel et al., *Nature* 281:544, 1979), tryptophan (trp) promoter system (Goeddel et al., *Nucl. Acids Res.* 8:4057, 1980; and EP-A-36776) and tac promoter (Maniatis, *Molecular Cloning: A Laboratory Manual*, Cold Spring Harbor Laboratory, p. 412, 1982). A particularly useful prokaryotic host cell  
25 expression system employs a phage  $\lambda$  P<sub>L</sub> promoter and a cI857ts thermolabile repressor sequence. Plasmid vectors available from the American Type Culture Collection which incorporate derivatives of the  $\lambda$  P<sub>L</sub> promoter include plasmid pHUB2 (resident in *E. coli* strain JMB9, ATCC 37092) and pPLc28 (resident in *E. coli* RR1, ATCC 53082).

Soluble CD39 may also be expressed in yeast host cells, preferably from the *Saccharomyces*  
30 genus (e.g., *S. cerevisiae*). Other genera of yeast, such as *Pichia* or *Kluyveromyces*, may also be employed. Yeast vectors will often contain an origin of replication sequence from a 2 $\mu$  yeast plasmid, an autonomously replicating sequence (ARS), a promoter region, sequences for polyadenylation, sequences for transcription termination, and a selectable marker gene. Suitable promoter sequences for yeast vectors include, among others, promoters for metallothionein, 3-phosphoglycerate kinase  
35 (Hitzeman et al., *J. Biol. Chem.* 255:2073, 1980) or other glycolytic enzymes (Hess et al., *J. Adv. Enzyme Reg.* 7:149, 1968; and Holland et al., *Biochem.* 17:4900, 1978), such as enolase, glyceraldehyde-3-phosphate dehydrogenase, hexokinase, pyruvate decarboxylase,

phosphofructokinase, glucose-6-phosphate isomerase, 3-phosphoglycerate mutase, pyruvate kinase, triosephosphate isomerase, phospho-glucose isomerase, and glucokinase. Other suitable vectors and promoters for use in yeast expression are further described in Hitzeman, EPA-73,657. Another alternative is the glucose-repressible ADH2 promoter described by Russell et al. (*J. Biol. Chem.* 5 258:2674, 1982) and Beier et al. (*Nature* 300:724, 1982). Shuttle vectors replicable in both yeast and *E. coli* may be constructed by inserting DNA sequences from pBR322 for selection and replication in *E. coli* (Amp<sup>r</sup> gene and origin of replication) into the above-described yeast vectors.

The yeast  $\alpha$ -factor leader sequence may be employed to direct secretion of recombinant polypeptides. The  $\alpha$ -factor leader sequence is often inserted between the promoter sequence and the structural gene sequence. See, e.g., Kurjan et al., *Cell* 30:933, 1982 and Bitter et al., *Proc. Natl. Acad. Sci. USA* 81:5330, 1984. Other leader sequences suitable for facilitating secretion of recombinant polypeptides from yeast hosts are known to those of skill in the art. A leader sequence may be modified near its 3' end to contain one or more restriction sites. This will facilitate fusion of the leader sequence to the structural gene.

Yeast transformation protocols are known to those of skill in the art. One such protocol is described by Hinnen et al., *Proc. Natl. Acad. Sci. USA* 75:1929, 1978. The Hinnen et al. protocol selects for Trp<sup>+</sup> transformants in a selective medium, wherein the selective medium consists of 0.67% yeast nitrogen base, 0.5% casamino acids, 2% glucose, 10  $\mu$ g/ml adenine and 20  $\mu$ g/ml uracil.

Yeast host cells transformed by vectors containing an ADH2 promoter sequence may be grown for inducing expression in a "rich" medium. An example of a rich medium is one consisting of 1% yeast extract, 2% peptone, and 1% glucose supplemented with 80  $\mu$ g/ml adenine and 80  $\mu$ g/ml uracil. Derepression of the ADH2 promoter occurs when glucose is exhausted from the medium.

Mammalian or insect host cell culture systems also may be employed to express recombinant CD39 polypeptides. Baculovirus systems for production of heterologous polypeptides in insect cells are reviewed by Luckow and Summers, *BioTechnology* 6:47, 1988. Established cell lines of mammalian origin may also be used. Examples of suitable mammalian host cell lines include the COS-7 line of monkey kidney cells (ATCC CRL 1651) (Gluzman et al., *Cell* 23:175, 1981), L cells, C127 cells, 3T3 cells (ATCC CCL 163), Chinese hamster ovary (CHO) cells, HeLa cells, and BHK (ATCC CRL 10) cell lines, and the CV1/EBNA cell line derived from the African green monkey kidney cell line CV1 (ATCC CCL 70) as described by McMahan et al. (*EMBO J.* 10: 2821, 1991). For the production of therapeutic polypeptides it is particularly advantageous to use a mammalian host cell line which has been adapted to grow in media that does not contain animal proteins. The use of such a cell line for the expression of soluble CD39 is described in Example 13.

Established methods for introducing DNA into mammalian cells have been described (Kaufman, R.J., *Large Scale Mammalian Cell Culture*, 1990, pp. 15-69). Additional protocols using commercially available reagents, such as Lipofectamine (Gibco/BRL) or Lipofectamine-Plus, can be used to transfect cells (Felgner et al., *Proc. Natl. Acad. Sci. USA* 84:7413-7417, 1987). In addition,

electroporation can be used to transfect mammalian cells using conventional procedures, such as those in Sambrook et al. *Molecular Cloning: A Laboratory Manual*, 2 ed. Vol. 1-3, Cold Spring Harbor Laboratory Press, 1989). Selection of stable transformants can be performed using methods known in the art, such as, for example, resistance to cytotoxic drugs. Kaufman et al., *Meth. in Enzymology* 5 185:487-511, 1990, describes several selection schemes, such as dihydrofolate reductase (DHFR) resistance. A suitable host strain for DHFR selection can be CHO strain DX-B11, which is deficient in DHFR (Urlaub and Chasin, *Proc. Natl. Acad. Sci. USA* 77:4216-4220, 1980). A plasmid expressing the DHFR cDNA can be introduced into strain DX-B11, and only cells that contain the plasmid can grow in the appropriate selective media. Other examples of selectable markers that can be 10 incorporated into an expression vector include cDNAs conferring resistance to antibiotics, such as G418 and hygromycin B. Cells harboring the vector can be selected on the basis of resistance to these compounds.

Transcriptional and translational control sequences for mammalian host cell expression vectors can be excised from viral genomes. Commonly used promoter sequences and enhancer 15 sequences are derived from polyoma virus, adenovirus 2, simian virus 40 (SV40), and human cytomegalovirus. DNA sequences derived from the SV40 viral genome, for example, SV40 origin, early and late promoter, enhancer, splice, and polyadenylation sites can be used to provide other genetic elements for expression of a structural gene sequence in a mammalian host cell. Viral early and late promoters are particularly useful because both are easily obtained from a viral genome as a 20 fragment, which can also contain a viral origin of replication (Fiers et al., *Nature* 273:113, 1978; Kaufman, *Meth. in Enzymology*, 1990). Smaller or larger SV40 fragments can also be used, provided the approximately 250 bp sequence extending from the *Hind* III site toward the *Bgl* I site located in the SV40 viral origin of replication site is included.

Additional control sequences shown to improve expression of heterologous genes from 25 mammalian expression vectors include such elements as the expression augmenting sequence element (EASE) derived from CHO cells (Morris et al., *Animal Cell Technology*, 1997, pp. 529-534) and the tripartite leader (TPL) and VA gene RNAs from Adenovirus 2 (Gingeras et al., *J. Biol. Chem.* 257:13475-13491, 1982). The internal ribosome entry site (IRES) sequences of viral origin allows dicistronic mRNAs to be translated efficiently (Oh and Sarnow, *Current Opinion in Genetics and 30 Development* 3:295-300, 1993; Ramesh et al., *Nucleic Acids Research* 24:2697-2700, 1996). Expression of a heterologous cDNA as part of a dicistronic mRNA followed by the gene for a selectable marker (e.g. DHFR) has been shown to improve transfectability of the host and expression of the heterologous cDNA (Kaufman, *Meth. in Enzymology*, 1990). Exemplary expression vectors that employ dicistronic mRNAs are pTR-DC/GFP described by Mosser et al., *Biotechniques* 22:150- 35 161, 1997, and p2A5I described by Morris et al., *Animal Cell Technology*, 1997, pp. 529-534.

A useful high expression vector, pCAVNOT, has been described by Mosley et al., *Cell* 59:335-348, 1989. Other expression vectors for use in mammalian host cells can be constructed as disclosed by Okayama and Berg (*Mol. Cell. Biol.* 3:280, 1983). A useful system for stable high level

expression of mammalian cDNAs in C127 murine mammary epithelial cells can be constructed substantially as described by Cosman et al. (*Mol. Immunol.* 23:935, 1986). A useful high expression vector, PMLSV N1/N4, described by Cosman et al., *Nature* 312:768, 1984, has been deposited as ATCC 39890. Additional useful mammalian expression vectors are described in EP-A-0367566, and  
5 in U.S. Patent Application Serial No. 07/701,415, filed May 16, 1991, incorporated by reference herein. The vectors can be derived from retroviruses. In place of the native signal sequence, a heterologous signal sequence can be added, such as the signal sequence for IL-7 described in United States Patent 4,965,195; the signal sequence for IL-2 receptor described in Cosman et al., *Nature* 312:768, 1984; the IL-4 signal peptide described in EP 367,566; the type I IL-1 receptor signal peptide  
10 described in U.S. Patent 4,968,607; and the type II IL-1 receptor signal peptide described in EP 460,846.

Another useful expression vector, pFLAG, can be used. FLAG<sup>®</sup> technology is centered on the fusion of a low molecular weight (1kD), hydrophilic, FLAG<sup>®</sup> marker peptide to the N-Terminus of a recombinant polypeptide expressed by the pFLAG-1<sup>™</sup> Expression Vector (obtained from IBI  
15 Kodak).

#### F. Purification of soluble CD39 Polypeptides

Soluble CD39 polypeptides may be prepared by culturing transformed host cells under culture conditions necessary to express CD39 polypeptides. The resulting expressed polypeptides may then  
20 be purified from culture media or cell extracts. Supernatant fluid from the cultured, transformed host cells may be concentrated using a commercially available protein concentration filter, for example, an Amicon or Millipore Pellicon ultrafiltration unit. Following the concentration step, the concentrate may be applied to a cation exchange matrix. Suitable cation exchangers include various insoluble matrices comprising sulfonic or carboxymethyl groups; sulfonic groups are preferred. The matrices  
25 can be acrylamide, agarose, dextran, cellulose or other types commonly employed in protein purification. Subsequently, an anion exchange resin is employed, for example, a matrix or substrate having pendant diethylaminoethyl (DEAE) or quaternary amino groups; quaternary amino groups are preferred. The matrices can be acrylamide, agarose, dextran, cellulose or other types commonly employed in protein purification. Additionally, a gel filtration medium may be employed to further  
30 purify CD39 polypeptides according to approximate molecular weight. Alternatively, certain of these steps may not be performed, or may be performed in the reverse order.

One or more reverse-phase high performance liquid chromatography (RP-HPLC) steps employing hydrophobic RP-HPLC media, (e.g., silica gel having pendant methyl or other aliphatic groups) may be employed to further purify CD39. A substantially purified and homogeneous  
35 polypeptide having CD39 biological activity may be eluted from a polyacrylamide gel subsequent to electrophoretic separation. Some or all of the foregoing purification steps, in various combinations, can also be employed to provide a substantially purified and homogeneous recombinant polypeptide

containing less than about 1% by mass of protein contaminants residual of production processes, or alternatively, which is greater than about 95 % pure by gel electrophoresis.

Affinity chromatography may be utilized to purify soluble CD39. Affinity purification of soluble CD39 from conditioned media is described in Example 12C. Moreover, small amounts of purified CD39 may be obtained by immunoprecipitating CD39 with a monoclonal antibody, electrophoresing the immunoprecipitate on a polyacrylamide gel, excising the portion of the gel containing the CD39, and eluting the CD39 from the excised portion of the gel.

Recombinant polypeptides produced in bacterial culture are generally isolated by disruption of the host cells, centrifugation, extraction from cell pellets if an insoluble polypeptide, or from the supernatant fluid if a soluble polypeptide, followed by one or more concentration, salting-out, ion exchange, affinity purification or size exclusion chromatography steps. Finally, RP-HPLC can be employed for final purification steps. Microbial cells can be disrupted by any convenient method, including freeze-thaw cycling, sonication, mechanical disruption, or use of cell lysing agents.

Transformed yeast host cells may be employed to express CD39 as a secreted polypeptide. This simplifies purification. Secreted recombinant polypeptide from a yeast host cell fermentation can be purified by methods analogous to those disclosed by Urdal et al. (*J. Chromatog.* 296:171, 1984). Urdal et al. describe two sequential, reversed-phase HPLC steps for purification of recombinant human IL-2 on a preparative HPLC column.

The desired degree of purity of soluble CD39 polypeptides depends on the intended use of the polypeptide. A relatively high degree of purity is desired when the polypeptide is to be administered in vivo, for example. Advantageously, soluble CD39 polypeptides are purified such that no protein bands corresponding to other (non-CD39) polypeptides are detectable upon analysis by SDS-polyacrylamide gel electrophoresis (SDS-PAGE). Following electrophoresis, the protein band may be visualized by silver staining, Coomassie blue staining, or (if the protein is radiolabeled) by autoradiography. It will be recognized by one skilled in the pertinent field that multiple bands corresponding to CD39 polypeptide may be visualized by SDS-PAGE, due to differential glycosylation, differential post-translational processing, and the like.

#### G. Therapeutic Compositions of CD39 Polypeptides

The present invention provides compositions comprising an effective amount of a soluble CD39 polypeptide in a pharmaceutically acceptable carrier. As used herein, the terms "therapy," "therapeutic," "treat," and "treatment" generally include prophylaxis, i.e., prevention, of a disease or condition in addition to therapy or treatment for an extant disease or condition. Therapeutic compositions of soluble CD39 polypeptides may therefore need to be administered before, during, or after the presentation of symptoms. For therapeutic use, a soluble CD39 polypeptide is administered to a patient for treatment in a manner appropriate to the indication. Thus, for example, soluble CD39 pharmaceutical compositions which are administered to achieve a desired therapeutic effect can be given by bolus injection, continuous infusion, sustained release from implants or the like, or other



suitable technique. Ideally, development of a stable form of CD39 or closely related biologically active variant would allow its use in oral form, a preferable route of administration. Since CD39 is aspirin-insensitive, these two therapeutic agents (CD39 compositions and aspirin) can be used in combination, for maximal benefit.

5           Typically, a soluble CD39 therapeutic agent will be administered in the form of a pharmaceutical composition comprising purified soluble CD39 in conjunction with physiologically acceptable carriers, including excipients or diluents. Such carriers will be nontoxic to patients at the dosages and concentrations employed. As described in the examples that follow, the administration of CD39 in murine and porcine models of thrombosis does not cause any observable toxic effects.

10          Moreover, a second dose of CD39 does not evoke any signs of immunogenicity. Ordinarily, the preparation of such compositions entails combining a soluble CD39 composition with buffers, antioxidants such as ascorbic acid, low molecular weight (less than about 10 residues) polypeptides, polypeptides, amino acids, carbohydrates including glucose, sucrose or dextrans, chelating agents such as EDTA, glutathione and other stabilizers and excipients. Neutral buffered saline or saline mixed

15          with conspecific serum albumin are exemplary appropriate diluents.

            One type of sustained release technology which may be used in administering soluble CD39 compositions is that utilizing hydrogel materials, for example, photopolymerizable hydrogels (Sawhney et al., *Macromolecules* 26:581; 1993). Similar hydrogels have been used to prevent postsurgical adhesion formation (Hill-West et al., *Obstet. Gynecol.* 83:59, 1994) and to prevent

20          thrombosis and vessel narrowing following vascular injury (Hill-West et al., *Proc. Natl. Acad. Sci. USA* 91:5967, 1994). Polypeptides can be incorporated into such hydrogels to provide sustained, localized release of active agents (West and Hubbel, *Reactive Polymers* 25:139, 1995; Hill-West et al., *J. Surg. Res.* 58:759; 1995). The sustained, localized release of CD39 when incorporated into hydrogels would be amplified by the long half life of CD39, which is demonstrated in the Examples

25          below.

            Accordingly, the soluble CD39 compositions described herein can also be incorporated into hydrogels, for application to tissues for which localized inhibition of hemostasis is desirable. For example, a hydrogel incorporating a CD39 polypeptide can be applied to tissue after surgery, to prevent or reduce post-surgical adhesion formation, or can be applied using a catheter-based delivery

30          system following angioplasty to prevent or reduce restenosis. Those of skill in the art will be able to formulate an appropriate hydrogel by applying standard pharmacokinetic studies, for example as discussed in West and Hubbell, *supra*.

            Effective amounts may vary, depending on the age, type and severity of the condition to be treated, body weight, desired duration of treatment, method of administration, and other parameters.

35          Effective dosages are determined by a physician or other qualified medical professional. Typical dosages are 0.01-100 mg/kg body weight, preferably 0.1-10 mg/kg body weight. In some embodiments a single administration is sufficient; in some embodiments the soluble CD39 polypeptide is administered on a daily basis for up to a week or as much as a month or more.

The biological effectiveness of soluble CD39 polypeptides is easily evaluable: at given time intervals after administration, a prolongation of the bleeding time in the setting of unchanged platelet count should be measurable if released platelet ADP has been metabolized by the CD39 composition administered. This would indicate that a therapeutic effect has likely been obtained, as said  
5 measurement correlates with clinical improvement. A therapeutic effect can also be validated by testing platelet reactivity to ADP and other platelet agonists *ex vivo*. Actual measurements of enzyme (apyrase) activity can also be made following administration of soluble CD39. These and other methods of measuring biological effectiveness are illustrated in the Examples below.

#### 10 H. Abbreviations Used in the Specification

ACR, apyrase conserved regions;  
AG, Affigel beads;  
ASA, acetylsalicylic acid;  
ATPDase, ATP diphosphohydolase;  
15 CHO, Chinese hamster ovary;  
CM, conditioned medium;  
DHFR, dihydrofolate reductase;  
FSBA, fluorosulfonylbenzoyl-adenosine;  
HUVEC, human umbilical vein endothelial cells;  
20 PRP, platelet-rich plasma;  
PTCA, percutaneous transluminal coronary angioplasty;  
solCD39, recombinant soluble human CD39;  
TBS, Tris-buffered saline

25

#### EXAMPLES

The following examples are intended to illustrate particular embodiments and not to limit the scope of the invention.

30

#### **EXAMPLE 1** **Assay For CD39 Expression**

This example describes the use of a monoclonal antibody in a FACS assay to analyze expression of CD39. The B73 mAb, a monoclonal anti-CD39, is a murine IgG1 that was derived from BALB/c mice immunized with the RPMI 1788 cell line (Rector et al., *Immunology* 55:481, 1985) and characterized as CD39-specific by flow cytometric analysis and immunoprecipitation/SDS-PAGE.  
35 Monoclonal anti-CD39 is purified from ascites fluid by affinity chromatography using a protein A column, eluted with 0.05 M sodium citrate, pH 3.0, neutralized and stored a 4°C at a concentration of about 1 mg/ml.

Cells to be analyzed (e.g., MP-1 cells, U937 cells, U937 cells stimulated with 5 ng/ml phorbol myristate acetate (PMA), or Daudi cells) are suspended to a concentration of  $10^6$  cell in 50  $\mu$ l of phosphate buffered saline (PBS) containing 100  $\mu$ g/ml human IgG1, and incubated for 30 minutes. The cells are then pelleted by centrifugation, resuspended in PBS/azide containing a first antibody  
5 (anti-CD39 or control antibody) and incubated (i.e., for 30 minutes at 4°C) The cells are then washed two times in PBS/azide, resuspended, and incubated with a labeled second antibody, for example, goat anti-murine immunoglobulin conjugated to phycoerythrin, then washed again. The cells are analyzed by flow cytometry, and levels of CD39 determined.

10

### EXAMPLE 2 Immunoselection of Cells Expressing CD39

This example describes a panning (immunoselection) technique for cells expressing CD39. For the preparation of pan plates, purified anti-CD39 or control antibody is diluted in phosphate buffered saline containing 0.1% heat-inactivated fetal calf serum (PBS/FCS). A titration of anti-CD39  
15 can be performed to determine the most effective concentration of anti-CD39. Pan plates are prepared by adding three ml of antibody solution or PBS/FCS alone to each plate. The plates are incubated for approximately one hour at room temperature, washed five times with PBS/FCS, and three ml of PBS/FCS containing 0.02% sodium azide are added to each plate.

The cells to be analyzed (e.g., MP-1, U937, or Daudi cells) are suspended in PBS/500  $\mu$ M  
20 EDTA/0.02% sodium azide (PEA) containing 5% goat serum, 5% rabbit serum and 100  $\mu$ g/ml human IgG1, to a concentration of  $2 \times 10^6$  cells/ml; 500  $\mu$ l of each cell suspension is added to the prepared pan plates. The pan plates are incubated with the cell suspension for approximately two hours at room temperature, then the plates are washed gently three times with PEA containing 10% FCS (PEA/FCS), and three times with PEA. The plates are examined with a microscope, and the relative number of  
25 cells bound to each plate is determined.

### EXAMPLE 3 cDNA Library Construction

This example describes preparation of a cDNA library from a human B cell line referred to as  
30 MP-1, for expression cloning of human CD39.

The library construction techniques were substantially similar to that described by Ausubel et al., eds., *Current Protocols In Molecular Biology*, Vol. 1, 1987. Briefly, total RNA was extracted from 8M guanidine HCl-lysed MP-1 cell cultures using differential ethanol precipitation and poly  
35 (A)<sup>+</sup> mRNA was isolated and enriched by oligo dT cellulose chromatography. Double-stranded cDNA was made from an RNA template substantially as described by Gubler et al., *Gene* 25:263, 1983. Poly(A)<sup>+</sup> mRNA fragments were converted to RNA-cDNA hybrids using reverse transcriptase primed with random hexanucleotides. The RNA-cDNA hybrids were then converted into double-

stranded cDNA fragments using RNAase H in combination with DNA polymerase I. The resulting double-stranded cDNA was blunt-ended with T4 DNA polymerase.

Unkinased (i.e. unphosphorylated) *Bgl*II adaptors were ligated to 5' ends of the above blunt-ended cDNA duplexes, using the adaptor cloning method described in Haymerle et al., *Nucleic Acids Res.* 14:8615, 1986. Under the described conditions, only the 24-mer oligonucleotide (top strand) will covalently bond to the cDNA during the ligation reaction. The non-covalently bound adaptors (including the complementary 20-mer oligonucleotide described above and any unligated adaptors) were removed by gel filtration chromatography at 65°C, leaving 24 nucleotide non-self-complementary overhangs on the cDNA termini.

The adapted cDNA was inserted into adapted pDC303, a mammalian expression vector that also replicates in *E. coli*. pDC303 was assembled from pDC201 (a derivative of pMLSV, previously described by Cosman et al., *Nature* 312: 768, 1984), SV40 and cytomegalovirus DNA and comprises, in sequence with the direction of transcription from the origin of replication, the following components: (1) SV40 sequences from coordinates 5171-270 containing the origin of replication, enhancer sequences and early and late promoters; (2) cytomegalovirus promoter and enhancer regions (nucleotides 671-63 from the sequence published by Boechar et al. (*Cell* 41:521, 1985); (3) adenovirus-2 from coordinates 5779-6079 containing the first exon of the tripartite leader (TPL), segment 7101-7172 and 9634-9693 containing the second exon and part of the third exon of the TPL and a multiple cloning site (MCS) containing sites for *Xho*I, *Kpn*I, *Sma*I and *Bgl*II; (4) SV40 segments from coordinates 4127-4100 and 2770-2533 containing the polyadenylation and termination signals for early transcription; (5) adenovirus-2 sequences from coordinates 10532-11156 of the virus-associated RNA genes VAI and VAII of pDC201; and (6) pBR322 sequences from coordinates 4363-2486 and 1094-375 containing the ampicillin resistance gene and origin of replication.

The MP-1 cDNA library in pDC303 was introduced into *E. coli* strain DH10B by electroporation. Recombinants were plated to provide approximately 5,000 colonies per plate. These recombinants were pooled to give a bulk stock of approximately 500,000 recombinants for screening. DNA was prepared from transformed bacteria and isolated by cesium chloride centrifugation.

#### EXAMPLE 4 Molecular Cloning of Human CD39 cDNA

This example describes the isolation of a DNA molecule encoding CD39 from the expression cloning library described in Example 3.

##### A. Round I: Transfection and Immunoselection

The isolated plasmid DNA was transfected into a sub-confluent layer of COS-7 cells using DEAE-dextran and a chloroquine treatment substantially according to the procedures described in McMahan et al., *EMBO J.* 10:2821; 1991.

COS-7 cells were maintained in transfection and growth medium (Dulbecco's modified Eagles' medium containing 10% (v/v) fetal calf serum, 50 U/ml penicillin, 50 µg/ml streptomycin, 2

mM L-glutamine and 50 µg/ml gentamicin) and were plated to a density of approximately  $1.5 \times 10^6$  cells in 10 ml transfection and growth medium in 10 cm dishes. Medium was removed from adherent cells growing in a layer to approximately 70% confluency, and replaced with 10 ml complete medium containing 66.5 µM chloroquine. About 500 µl of a DNA solution (5 µg DNA, 0.5 mg/ml DEAE-dextran in transfection and growth medium containing 66.5 µM chloroquine) was added to the cells and the mixture was incubated at 37°C in 10 % CO<sub>2</sub> for about five hours.

Following incubation, media was removed and the cells were shocked by addition of 5 ml transfection and growth medium containing 10% DMSO (dimethylsulfoxide) for 2.5 - 20 minutes. Shocking was followed by replacement of the solution with 10 ml fresh transfection and growth medium. Twelve plates of cells were grown in culture for two to three days to permit transient expression of the inserted DNA sequences. The cells were trypsinized after about 24 hours of growth in order to remove them from the plates. After an additional one to two days, cells expressing CD39 were selected by panning, essentially as described in Example 2. The cells were incubated in the mAb 73 pan plates for two hours at room temperature, after which unbound cells were removed by gently rinsing three times with PEA/FCS, then three times with PEA.

The cells that were not removed by rinsing were expressing CD39; cells expressing CD39 were lysed by the addition of 700 µl lysing buffer containing sodium dodecyl sulfate (SDS) and incubation for 20 minutes at room temperature. Lysates were transferred from each dish to individual microfuge tubes containing 100 µl of 5 M NaCl. The tubes were capped, mixed thoroughly by inverting about 20 times, and stored at 4°C overnight. After overnight incubation at 4°C, high molecular weight DNA (debris) was removed by centrifugation, and 2 µg of glycogen was added to each supernatant. The supernatants were then extracted twice with phenol/chloroform and once with chloroform/isoamyl alcohol. DNA was ethanol precipitated, washed with 80% ethanol, and vacuum dried. The purified DNA was then electroporated into *E. coli*, which were then plated out on ampicillin plates. A large-scale transformation was carried out in this manner, yielding a total of approximately 48,000 colonies (sub-library 1). DNA was prepared from the colonies using CsCl; frozen stocks of the colonies were prepared at the same time.

#### B. Round II: Electroporation and Immunoselection

The DNA from sub-library 1 was electroporated into COS cells (10 x 10 cm plates). Transfected COS cells were incubated, harvested and panned substantially as described for Round I above. DNA was isolated and a sub-library (sub-library 2) of approximately 50,000 independent colonies was prepared substantially as described above.

#### C. Round III: Electroporation and FACS Selection

The DNA from sub-library 2 was electroporated into COS cells (10 x 10 cm plates). Transfected COS cells were incubated and harvested substantially as described for Round I above. The harvested cells were analyzed by FACS substantially as described in Example 1 above. A small subpopulation of cells expressing CD39 was observed, and was sorted out from the larger mixture of

cells; DNA was isolated from the sorted cells. A sub-library (sub-library 3) of approximately 5,000 independent colonies was prepared. The DNA was pooled into 10 pools of approximately 500 colonies each; isolated DNA and frozen stocks of bacteria were prepared for each pool.

#### D. Round IV: Transfection and Immunoselection

5           The DNA from sub-library 3 was transfected into COS cells using DEAE-dextran and chloroquine treatment, and incubated, substantially as described for Round I above, except that the cells were incubated on fibronectin-treated, chambered slides (10 slides, 1 for each pool, and 4 control slides) instead of 10 cm plates. After two days of growth, the cells were harvested as described, and analyzed by FACS substantially as described in Example 1 above, as well as by a slide dipping  
10           technique. In the slide dipping technique, the slides were incubated with <sup>125</sup>I-labeled mAb 73 and fixed with glutaraldehyde. The results were determined by autoradiography using light microscopy to detect cell containing silver granules.

            Two pools containing approximately 500 individual clones each were identified as potentially positive for production of CD39. The pools were titered and plated to provide plates containing an  
15           average of approximately 150 colonies each. A replicate nitrocellulose filter was prepared from each plate; each plate was then scraped to provide smaller pools of plasmid DNA.

#### E. Round V: Transfection and Immunoselection

            COS-7 cells were transfected with the DNA from the smaller pools by DEAE-dextran, according to the same procedure described above. The transfected cells were screened by slide  
20           dipping and FACS as described previously. Two of the smaller pools contained clones that were positive for CD39 as indicated by the presence of an expressed gene product that bound mAb 73.

            A total of 156 colonies was picked from the replicate filter corresponding to one of the positive smaller pools, and inoculated into culture medium for overnight growth. After overnight  
25           growth, the cultures were arranged in a matrix format of 12 rows and 13 columns. Subpools of culture medium were prepared by pooling medium from each row and each column for a total of 24 subpools. The subpools were used to prepare DNA for a final round of transfection and screening. An intersection of a positive row and a positive column indicated a potential positive colony. One potential positive colony (i.e. clone) was identified.

            A streak plate was prepared from the positive clone (clone 1), and minipreps of DNA were  
30           made from nine individual colonies from the streak plate. The DNA was digested with Bgl II and analyzed by SDS-PAGE. Nine of nine individual colonies from clone 1 contained identical inserts of 1.8 - 2.0 Kb. A single isolate that contained the 1.8 - 2.0 Kb insert was picked and inoculated into 10 ml culture medium for overnight growth. DNA was prepared and sequenced by dideoxynucleotide sequencing. The nucleotide and deduced amino acid sequence of clone 1 is given in SEQ ID NO:1. A  
35           cloning vector containing human CD39 sequence, designated pCD39 was deposited with the American Type Culture Collection, Rockville, MD (ATCC) on September 29, 1992, under the Budapest Treaty, and assigned accession number 69077. A murine homolog of CD39 was isolated by

cross-species hybridization; the amino acid sequence of the murine homolog is described in Maliszewski et al., *J. Immunol.* 153:3574, 1994.

**EXAMPLE 5**  
**Preparation of CD39 mAbs**

5

This example describes the preparation of additional monoclonal antibodies against CD39, including antibodies against the region that contains apyrase activity. Preparations of purified CD39 fragments exhibiting ADPase activity, for example, or transfected cells expressing such CD39 polypeptides, are employed as immunogens to generate monoclonal antibodies against CD39 using conventional techniques, such as those disclosed in U.S. Patent 4,411,993. DNA encoding CD39 fragments can also be used as an immunogen, for example, as reviewed by Pardoll and Beckerleg in *Immunity* 3:165, 1995. Such antibodies are useful for interfering with CD39-induced platelet aggregation, as components of diagnostic or research assays for CD39 or CD39 activity, and in affinity purification of CD39.

10

To immunize rodents, CD39 immunogen is emulsified in an adjuvant (such as complete or incomplete Freund's adjuvant, alum, or another adjuvant, such as Ribi adjuvant R700 (Ribi, Hamilton, MT), and injected in amounts ranging from 10-100  $\mu$ g subcutaneously into a selected rodent, for example, BALB/c mice or Lewis rats. DNA may be given intradermally (Raz et al., *Proc. Natl. Acad. Sci. USA* 91:9519, 1994) or intramuscularly (Wang et al., *Proc. Natl. Acad. Sci. USA* 90:4156, 1993); saline has been found to be a suitable diluent for DNA-based antigens. Ten days to three weeks days later, the immunized animals are boosted with additional immunogen and periodically boosted thereafter on a weekly, biweekly or every third week immunization schedule.

15

20

Serum samples are periodically taken by retro-orbital bleeding or tail-tip excision for testing by dot-blot assay (antibody sandwich), ELISA (enzyme-linked immunosorbent assay), immunoprecipitation, or other suitable assays, including FACS analysis. Following detection of an appropriate antibody titer, positive animals are given an intravenous injection of antigen in saline. Three to four days later, the animals are sacrificed, splenocytes harvested, and fused to a murine myeloma cell line (e.g., NS1 or preferably Ag 8.653 [ATCC CRL 1580]). Hybridoma cell lines generated by this procedure are plated in multiple microtiter plates in a selective medium (for example, one containing hypoxanthine, aminopterin, and thymidine, or HAT) to inhibit proliferation of non-fused cells, myeloma-myeloma hybrids, and splenocyte-splenocyte hybrids.

25

30

Hybridoma clones thus generated can be screened by ELISA for reactivity with CD39, for example, by adaptations of the techniques disclosed by Engvall et al., *Immunochem.* 8:871, 1971 and in U.S. Patent 4,703,004. A preferred screening technique is the antibody capture technique described by Beckman et al., *J. Immunol.* 144:4212, 1990. Positive clones are then injected into the peritoneal cavities of syngeneic rodents to produce ascites containing high concentrations (>1 mg/ml) of anti-CD39 monoclonal antibody. The resulting monoclonal antibody can be purified by ammonium sulfate precipitation followed by gel exclusion chromatography. Alternatively, affinity chromatography based

35

upon binding of antibody to protein A or protein G can also be used, as can affinity chromatography based upon binding to CD39 polypeptide. An alternative strategy is to employ full-length CD39 immunogen, selecting for antibodies that bind CD39, and winnowing out those that bind to previously defined epitopes, for example by screening with a fragment of CD39 that represents a previously defined epitope.

Monoclonal antibodies are also prepared by immunizing CD39 knockout mice, such as those described in Example 19D, with CD39 immunogen. Since the entire CD39 sequence is seen as "foreign" in the knockout mice, this strategy can lead to the generation of antibodies recognizing epitopes that are shared across species lines, including antibodies that antagonize or agonize CD39 bioactivity.

#### EXAMPLE 6 Physiological Activity of CD39

This example demonstrates that CD39 is the endothelial cell ecto-ADPase responsible for inhibition of platelet function. Human umbilical vein endothelial cells (HUVEC) constitutively inhibit platelet responsiveness to prothrombotic stimuli by catabolism of exogenous platelet-derived ADP. The endothelial ecto-ADPase has been identified as CD39 (Marcus et al., *J. Clin. Invest.* 99:1351, 1997). Anti-CD39 antibodies immunoprecipitated ADPase activity from a preparation derived from endothelial membranes, and COS cells transfected with an expression vector comprising CD39 acquired ecto-ADPase activity whereas COS cells transfected with a control vector did not. Ecto-ADPase activity was measured in a manner similar to that described in Marcus et al., *J. Clin. Investigation* 88:1690, 1991, by conversion of  $^{14}\text{C}$ -ADP to AMP by transfectant monolayers as well as membrane preparations, and was greater than or comparable to activity of intact HUVEC monolayers and solubilized membranes

HUVEC mRNA was analyzed by RT-PCR using primer pairs derived from the sequence of the human CD39 lymphoid cell activation antigen with emphasis on its N-terminal portion. Lymphoid CD39 cDNA was used for direct comparison of PCR product sizes. The data demonstrated identity between HUVEC and lymphoid CD39 in the 4 fragments spanning the portion analyzed (approximately 1250 of the 1850 bp of lymphoid CD39). Northern blot analyses revealed that the mRNA for CD39 in HUVEC was expressed in the same band pattern as in MP-1 cells, from which CD39 was originally cloned.

Confocal microscopy and fluorescence activated cell sorting, using mAb73, were used to determine if HUVEC cells expressed CD39. The FACS protocol was substantially as described in Example 1. For confocal microscopy, cells (human umbilical vein endothelial or transfected COS-1 cells) grown on coverslip glass were washed with PBS and fixed with 3% paraformaldehyde for 30 minutes at room temperature. Auto fluorescence was quenched by treatment with 50mM  $\text{NH}_4\text{Cl}$  for 10 minutes. Cells were then incubated in PBS containing 5% NGS (normal goat serum) plus 0.1% triton X-100 to block non-specific binding and to permeabilize cells. Cells were then incubated with



anti-CD39 antibody at 5 µg/ml in PBS containing 5% NGS +0.1% triton X-100 for 1 hour at room temperature. Following three washes with PBS containing 5% NGS +0.1% triton X-100 cells were incubated with goat anti-mouse labeled with Texas Red (Molecular Probes) at 5 µg/ml in addition to 10 mM YOYO (Molecular Probes) for nucleic acid counter stain, for 1 hour at room temperature.

5 Cells were washed 3 times with PBS containing 5% NGS +0.1% triton X-100 and mounted in 100 mg/ml DABCO (1,4 diaxabicyclo [2.2.2] octane) (Sigma) in 50% glycerol. Cells were then viewed with Multiprobe 2001 laser scanning confocal microscope (Molecular Dynamics). One image was collected of CD39 staining (Texas Red) and a second image was collected of cell nuclei (YOYO).

Both the confocal microscopy and FACS experiments demonstrated that HUVEC express  
10 CD39. The patterns of expression were similar to those seen in cells transfected with full-length human CD39.

The physiological activity of CD39 was illustrated by the ability of CD39-transfected COS cells to inhibit and completely reverse platelet aggregation by 10 µM ADP. CD39-transfected COS cells, as well as MP-1 cells and HUVEC, metabolized this quantity of ADP to AMP within three to  
15 four minutes and, when added to platelet rich plasma (substantially as described in Marcus et al., *supra*), they rapidly reversed platelet aggregation. This activity occurred within the time frame of platelet adhesion to injured subendothelium, a process leading to immediate ADP release, recruitment of additional platelets and formation of a hemostatic plug or thrombus. This time course paralleled platelet inhibition by CD39-expressing cells, and was commensurate with their ADPase activities.

20 The activity of ADPase/CD39 was independent of formation of other known thromboregulators, nitric acid or prostacyclin. These results demonstrate the importance of ADPase/CD39 as a physiological, constitutively expressed endothelial cell thromboregulator.

#### EXAMPLE 7

##### 25 Phosphate Release Assay for ATPase Activity

This example describes an ATPase assay that may be used to track enzyme activity. Samples (approximately 100 µl of either concentrated CM or purified polypeptide) are combined with 20 µl of 10X assay buffer (200 mM HEPES, 1.2 M NaCl, 50 mM KCl, 15 mM CaCl<sub>2</sub>, 15 mM MgCl<sub>2</sub> and 3 mM ATP) and sterile water is added to a final volume of 200 µl. Radiolabeled ATP (0.8 µCi γ [<sup>32</sup>P]  
30 ATP; Amersham, Arlington Heights, IL) is added and the mixture incubated for 20 minutes at 37°C. Stop mix (0.5 ml of 20% activated charcoal/1 M HCl) is added and the reaction is placed on ice for 10 minutes. After centrifugation (14K rpm for 10 minutes), the supernatant is assayed for free <sup>32</sup>P using a scintillation counter. Data are expressed as raw counts or net counts, or as picomoles of ATP degraded per minute.

#### EXAMPLE 8

##### 35 Binding Assay

This example describes an assay to assess the binding of CD39 polypeptides to CD39 antibodies by biospecific interaction analysis (BIA) using a biosensor, an instrument that combines a

biological recognition mechanism with a sensing device or transducer. An exemplary biosensor is BIAcore™, from Pharmacia Biosensor AB (Uppsala, Sweden; see Fägerstam L.G., *Techniques in Protein Chemistry II*, ed. J.J. Villafranca, Acad. Press, NY, 1991). BIAcore™ uses the optical phenomenon surface plasmon resonance (Kretschmann and Raether, *Z. Naturforschung, Teil. A* 23:2135, 1968) to monitor the interaction of two biological molecules. Molecule pairs having affinity constants in the range  $10^5$  to  $10^{10}$  M<sup>-1</sup>, and association rate constants in the range of  $10^3$  to  $10^6$  M<sup>-1</sup>s<sup>-1</sup>, are suitable for characterization with BIAcore™.

The biosensor chips are coated with CD39 antibody (e.g., mAb73). The different constructs of CD39 to be assessed are then added at increasing concentrations; the chip is regenerated between the different constructs, for example, by the addition of sodium hydroxide. The resultant data can be analyzed to qualitatively or quantitatively assess production of CD39 polypeptides. Affinity of the CD39 polypeptides for the CD39 antibodies can also be determined. In a similar manner, other monoclonal antibodies or polypeptides that specifically bind CD39 can be immobilized on a biosensor chip to assess the binding of various CD39 polypeptides.

#### EXAMPLE 9

##### Transient Expression of Soluble CD39 Polypeptides

This example describes the preparation of constructs for the transient expression of soluble CD39 polypeptides.

##### A. Reagents Used

The B73 mAb, a murine IgG1 recognizing human CD39, was kindly provided by Dr. Guy Delespesse (U. Montreal, Quebec, Canada). The M2 mAb recognizing the FLAG® peptide (DYKDDDDK, SEQ ID NO:10), a murine IgG1, was prepared at Immunex Corp. Affigel 10 (Bio-Rad, Hercules, CA) and CNBr-activated Sepharose 4B (Pharmacia Biotech, Piscataway, NJ) immunoaffinity columns were prepared according to manufacturers' instructions. Typically, coupling efficiencies in the range of 3-5 mg mAb per ml of affinity gel slurry were obtained.

##### B. Construction of a Soluble CD39 (solCD39) Expression Plasmid

To generate a soluble molecule having the properties of CD39 the N-terminal and C-terminal portions of CD39, including the two transmembrane regions (see Fig. 2), were removed. To allow transport of soluble CD39 into the medium, a leader sequence providing for secretion was added at the amino terminus of the polypeptide.

Constructs of soluble human CD39 (solCD39) were made in the mammalian expression vector pDC206 (Kozlosky et al. *Oncogene*. 10:299, 1995), utilizing human IL2 (huIL2), human growth hormone (huGH) and murine IL7 (muIL7) leaders.

The DNA sequences between the putative transmembrane regions of full-length CD39, including nucleotides 178-1494 of SEQ ID NO:1, were amplified using PCR and the C-terminal transmembrane coding region was replaced with a stop codon. The PCR product was fused to a synthetic DNA fragment encoding an 8 amino acid peptide tag (FLAG<sup>®</sup>) and ligated with a muIL7 leader (muIL7L) into the plasmid pDC206 vector via Spe1 and Bgl2 restriction sites. This construct encoded N-terminally FLAG-tagged solCD39.

Alternate leaders were introduced by ligating the Spe1/Bgl2 FLAG-solCD39 fragment into two different pDC206 plasmids, with leaders derived from: (1) human growth hormone (huGHL), and (2) a human proinsulin/IL2 fusion polypeptide (huIL2L, Cullen, *DNA*. 7:645, 1988). The coding region of the latter construct, which is shown in SEQ ID NOs:25 and 26, includes sequences encoding the huIL2 leader (huIL2L, nucleotides 1-72, amino acids 1-24 in SEQ ID NO:25), the first 12 amino acids of mature human IL2 (nucleotides 73-108, amino acids 25-36 in SEQ ID NO:25), a four amino acid linker (nucleotides 109-120, amino acids 37-40 in SEQ ID NO:25), the FLAG tag (nucleotides 121-144, amino acids 41-48 of SEQ ID NO:25), and sol CD39 (nucleotides 145-1461, amino acids 49-487 of SEQ ID NO:25).

The constructs comprising the muIL7 leader, the human growth hormone leader, and the human proinsulin/IL2 leader were designated pIL7LFlagSolCD39, pGHLFlagSolCD39, and pIL2LFlagSolCD39 respectively.

Each construct was used to transiently transfect subconfluent layers of COS-1 cells using DEAE dextran followed by chloroquine as described by Cosman et al., *Nature* 312:768, 1984. As a negative control, a CD40 ligand construct (pIL2LCD40lig, Spriggs et al., *J. Exp. Med.* 176:1543, 1992) was also transfected into COS-1 cells.

#### C. Preparation of Conditioned Medium from solCD39 Transfectants

The transfected COS-1 cells were incubated (37°C, 5% CO<sub>2</sub>) in 0.5% FCS-supplemented DMEM-F12 medium in 10 cm<sup>2</sup> Petri dishes or 175 cm<sup>2</sup> tissue culture flasks. After 5 days, conditioned medium (CM) from these cultures was collected, and cells and debris were removed by centrifugation. The CM was concentrated 4-10 fold using a pressurized, stirred cell fitted with a YM-10 (10 kD cutoff) membrane (Amicon Corp., Danvers, MA).

#### D. ATPase Activity in Conditioned Medium from solCD39 Transfectants

ATPase activity in the CM from solCD39 transfectants (100 µL of 10-fold concentrated supernatant) was assayed essentially as described in Example 7, except that the 10X assay buffer contained 30 mM cold ATP. The results are shown in TABLE 1.

The transfections were repeated and the CM (10, 20 and 30 µL, unconcentrated) was assayed essentially as described in Example 7. The results are shown in TABLE 2. Because the pIL2LFlagSolCD39 showed higher ATPase activity in COS-1 supernatants than pIL7LFlagSolCD39 and pGHLFlagSolCD39, this construct was selected for further investigation. ATPase levels in CM

from COS-1 cells transfected with pIL2LFlagSolCD39 increased with time in culture over at least 4 days post-transfection.

5

TABLE 1  
ATPase Activity in Concentrated CM from solCD39 Transfectants

Sample	CPM Release x 10 <sup>3</sup> (raw counts)
pIL2LFlagSolCD39	99.96
pIL7LFlagSolCD39	39.47
pGHLFlagSolCD39	21.14
pIL2LCD40lig	10.53
media only	7.89

TABLE 2  
ATPase Activity in CM from solCD39 Transfectants

Sample	Vol (μL)	CPM Release x 10 <sup>3</sup> (net counts)
pIL2LFlagSolCD39	10	24.71
	20	43.92
	30	56.93
pIL7LFlagSolCD39	10	5.01
	20	9.75
	30	14.23
pGHLFlagSolCD39	10	5.51
	20	7.22
	30	9.95

10 E. Immunoaffinity Depletion of solCD39 from COS-1 CM

To confirm that recombinant solCD39 accounted for the ATPase activity observed in the CM, CM from COS-1 transfectants was incubated with immunoaffinity beads prior to enzyme assay.

15 CM was collected from COS-1 cells transfected with pIL2LFlagSolCD39, which had been cultured for 5 days in DMEM/F12 supplemented with 5% FCS. A 100 μl aliquot of drained Affigel beads (AG) conjugated with either chicken ovalbumin, antiFLAG mAb, or anti-CD39 mAb was added per ml of CM. CM was subjected to one or two cycles of binding with one of the following: 20 ovalbumin-conjugated AG, M2 mAb-conjugated AG, or B73 mAb-conjugated AG. Each cycle involved continuous gentle agitation of the slurry for 14 h at 4°C followed by centrifugation to recover supernatants for a subsequent binding cycle or for ATPase activity measurements.

As shown in Fig. 3, immunoprecipitation with anti-CD39 mAb-conjugated beads resulted in removal of over 80% of ATPase activity from CM. Over 95% ATPase activity was removed with a second antibody adsorption step. Immunoprecipitation (2 cycles) with anti-FLAG mAb-coated beads also resulted in substantial depletion of enzyme activity. Two rounds of preincubation with a control (ovalbumin-conjugated beads) did not remove significant ATPase activity from the supernatants.

#### F. Immunoprecipitation of Recombinant solCD39

To characterize recombinant solCD39 polypeptide expression, COS-1 cells were transfected with mammalian expression vectors encoding cell surface CD39 (pHuCD39, Marcus et al., *J. Clin. Invest.* 99:1351, 1997), tagged soluble CD39 (pIL2LFlagSolCD39), or soluble CD40 ligand (pIL-2L-  
5 CD40L) and grown in 5% FCS-supplemented DMEM/F12 medium in 10 cm<sup>2</sup> dishes. Two days after transfection, the medium was replaced with Cys/Met-free medium and cells were incubated for 1 h at 37°C. The culture medium was replaced with fresh Cys/Met-free medium supplemented with 5 µl of [<sup>35</sup>S]-Cys/Met (Amersham, Arlington Heights, IL) in order to label newly synthesized polypeptides, and cells were cultured for 5 h at 37°C. CM from the metabolically radiolabeled cells was collected,  
10 purified of cells and debris by centrifugation and sterile filtration, and stored at 4°C until further use.

For radioimmunoprecipitation, 500 µl of <sup>35</sup>S-labeled CM was added to 250 µl of 3% BSA in Tris-buffered saline (TBS), pH 7.7, followed by addition of 50 µl of a 80% slurry of mAb-coated AG beads. In some cases, <sup>35</sup>S-labeled CM were incubated with ovalbumin-coated AG beads to remove nonspecifically binding materials prior to addition of Ab-coated beads. After incubation for 14 h at  
15 4°C, beads were removed by centrifugation and washed three times in cold TBS.

For SDS-PAGE analysis, 35 µl of 4-fold concentrated reducing sample buffer (250 mM Tris/HCl, pH 6.8, 8 % (w/v) SDS, 40 % (v/v) glycerol, 20% (v/v) 2-mercaptoethanol, 0.05% bromophenol blue dye) was added to each AG pellet, boiled for 5 min, and loaded onto a 8-16% Novex (San Diego, CA) polyacrylamide gel. Gels were electrophoresed at 25 mA, prepared for  
20 autoradiography by soaking in Enhance (NEN Life Science Products, Boston, MA) for 1 h and in H<sub>2</sub>O for 20 min, followed by vacuum drying at 80°C. Gels were exposed to Kodak (Rochester, NY) X-omat AR film for 2 h, then developed.

As shown in Fig. 4, IL-2L-FlagsolCD39 transfectants secreted a radiolabeled protein of ~66 kD that was recognized by anti-CD39. This protein was not detected in anti-CD39  
25 immunoprecipitated CM from COS-1 cells transfected with a vector encoding full-length CD39 (including N-terminal and C-terminal hydrophobic regions), or with a vector encoding a secreted protein, CD40 ligand. Anti-FLAG mAb immunoprecipitated a similar-sized band from CM of the pIL-2L FlagsolCD39 transfectant, consistent with the presence of the FLAG<sup>®</sup> peptide in recombinant solCD39. Preclearing radiolabeled culture supernatants with anti-ovalbumin-coated beads failed to  
30 remove the 66 kD band, indicating that binding to anti-CD39 and anti-FLAG was specific. Beads coated with an irrelevant, isotype matched control antibody failed to immunoprecipitate the 66 kD band from solCD39 containing CM.

#### G. Preparation of Additional solCD39 Fusion Constructs

35 Restriction enzymes were used to prepare a DNA fragment comprising nucleotides 1 through 1488 of SEQ ID NO:1, the coding region of which would be expected to encode a fragment of CD39 lacking the second (most C-terminal) transmembrane domain. Appropriate linker oligonucleotides

were prepared (SEQ ID NOs:14 and 15), and used in a three-way ligation of the CD39 DNA, the linker oligonucleotides, and an expression vector comprising regulatory elements allowing expression of a resulting fusion polypeptide in mammalian cells along with DNA encoding a mutated human immunoglobulin Fc (SEQ ID NOs:16 and 17) region that exhibits reduced affinity for Fc receptors  
5 (nucleotides 42 through 740 of SEQ ID NO:16). This construct was referred to as CD39Δ2Fc, and when transfected into cells resulted in the expression of a fusion polypeptide comprising amino acids 1 through 474 of SEQ ID NO:1 and amino acids 1 through 232 of SEQ ID NO:17, which could be detected on the surface of transfected cells using either anti-CD39 or anti-human IgG.

A PCR technique was employed to prepare a fragment of DNA from the CD39Δ2Fc construct  
10 that also lacked the first, most amino-proximal transmembrane region, but included CD39 DNA from nucleotides 181 through 1488 (amino acids 39 through 474) of SEQ ID NO:1 and the Fc mutein DNA from CD39Δ2Fc (using the linkers shown in SEQ ID NOs:18 and 19).

The resulting DNA was then ligated into an expression vector that included DNA encoding the murine Interleukin-7 leader sequence (SEQ ID NO:20) ligated immediately proximal to the CD39-  
15 encoding sequence. This construct was designated CD39Δ1,Δ2Fc.

DNA encoding the FLAG<sup>®</sup> peptide (SEQ ID NO:10) and a codon corresponding to nucleotides 178, 179 and 180 of SEQ ID NO:1 was inserted into the CD39Δ1,Δ2Fc construct, in between the leader sequence and the CD39-encoding sequence, to provide a detectable tag for the amino terminus of the fusion polypeptide (using the linkers shown in SEQ ID Nos:21 and 22). The  
20 tagged construct was referred to as FlagCD39Δ1,Δ2Fc.

Another construct was prepared that removed the Fc mutein sequences, and added codons corresponding to nucleotides 1489 through 1494 of SEQ ID NO:1 immediately downstream of the CD39 sequences (using the linkers shown in SEQ ID Nos:23 and 24). This construct was designated FlagCD39Δ1,Δ2.

25 Each of the constructs was transfected into mammalian cells and protein levels were assayed on the surface, in the interior, or in the supernatant fluid of transfected cells using antibodies to FLAG<sup>®</sup>, CD39, or human IgG.

#### EXAMPLE 10 Expression and Activity of pIL2LSolCD39

30 To facilitate the establishment of a stably producing transfectant in CHO cells, an untagged version of soluble human CD39 (solCD39) was constructed. A 523 bp SpeI/NdeI fragment containing the FLAG<sup>®</sup> tag and the first 163 amino acids (aa) of pIL2LFlagSolCD39 was removed, and replaced with a similar fragment from a C-terminally FLAG<sup>®</sup>-tagged solCD39. Thus the entire  
35 solCD39 coding region was reconstituted, sans FLAG<sup>®</sup>, while retaining the HuIL2 leader and mature IL2 residues. This construct was designated pIL2LSolCD39. The coding region of pIL2LSolCD39,

which is shown in SEQ ID NO:7, includes sequences encoding the huIL2 leader (huIL2L, nucleotides 1-72, amino acids 1-24 in SEQ ID NO:7), the first 12 amino acids of mature human IL2 (nucleotides 73-108, amino acids 25-36 in SEQ ID NO:7), a three amino acid linker (nucleotides 109-117, amino acids 37-39 in SEQ ID NO:7), and sol CD39 (nucleotides 118-1434, amino acids 40-478 of SEQ ID NO:7).

To determine whether activity was affected by removal of the N-terminal FLAG<sup>®</sup> tag, COS-1 cells were transfected with pIL2LFlagSolCD39 and pIL2LSolCD39 and supernatants (sups) were harvested after 5 days. Samples of 10, 20 and 30  $\mu$ L of 1x sups were assayed for ATPase activity as described in Example 7. As shown in TABLE 3, activity was not affected by removal of the N-terminal FLAG<sup>®</sup> tag.

**TABLE 3**  
ATPase Activity in CM from pIL2LFlagSolCD39 and pIL2LSolCD39 Transfectants

Sample	Vol ( $\mu$ L)	CPM x 10 <sup>3</sup> (net counts)
pIL2LFlagSolCD39	10	23.6
	20	40.2
	30	54.4
pIL2LSolCD39	10	20.1
	20	36.0
	30	51.0

15

**EXAMPLE 11**  
**Preparation of Additional solCD39 Fusion Constructs**

**A. Preparation and Characterization of Trim1 and Trim2 Variants**

To characterize the effect of the 12 mature human IL2 (huIL2) residues on the expression of solCD39, the huIL2 residues were removed during the construction of nucleic acid sequences encoding two additional variants of pIL2LSolCD39: pIL2LTrim1 ("Trim1") and pIL2LTrim2 ("Trim2").

The pIL2LTrim1 variant was constructed by purifying a Hind3/Bgl2 restriction fragment from pIL2LSolCD39 which contained the entire solCD39 coding region except for the first four amino acids. This fragment was ligated with a synthetic oligo cassette (containing the huIL2 leader and the first amino acid of mature huIL2) into Sma1/Bgl2 digested pDC206. The huIL2 leader was thus reintroduced and joined to solCD39 with an intervening alanine residue.

The pIL2LTrim2 variant was constructed in a similar fashion using a Spe1/Bgl2 fragment from pIL2LSolCD39 and a synthetic oligo cassette containing the huIL2 leader and the linker-encoded sequences (with the first codon altered to alanine). Thus, the huIL2 leader was restored with an intervening Ala-Ser-Ser linker preceding solCD39.

The N-terminal portions of the pIL2LSolCD39, pIL2LTrim1 and pIL2LTrim2 polypeptides are compared below, with the predicted cleavage points indicated as \*:

pIL2LSolCD39 (SEQ ID NO:11)  
MALWIDRMQLLSCIALSLALVTNS\*APTSSSTKKTQLts sT QNK...

5 pIL2LTrim1 (SEQ ID NO:12)  
MALWIDRMQLLSCIALSLALVTNS A T\*QNK...

10 pIL2LTrim2 (SEQ ID NO:13)  
MALWIDRMQLLSCIALSLALVTNS as\*sT QNK...

The polypeptide encoded by the Trim1 construct has the sequence SEQ ID NO:27. Residues 26-464 are a soluble portion of CD39 and the cleavage of the leader sequence is between Ser24 and Ala25.

15 The expression of Trim1 and Trim2 constructs was analyzed in COS-1 cells cultured in 10 cm plates. After 5 days of incubation, 1x supernatants were examined via ELISA (using anti-CD39) and the phosphate-release assay described in Example 7. As shown in TABLE 4, the specific activities (based on concentrations determined by ELISA) of Trim1 and Trim2 were equivalent to pIL2LFlagSolCD39. Expression levels, however, appeared to be reduced 3-4 fold.

20 TABLE 4  
SolCD39 Expression and Activity in CM from pIL2LSolCD39 an Trim Transfectants

Sample	[CD39] µg/mL	Activity (pmol ATP/min/µg) x 10 <sup>3</sup>
pIL2LSolCD39	0.75	5.67
pIL2LTrim1	0.21	8.38
pIL2LTrim2	0.21	6.67

25 COS-1 cells were also transfected with pIL2LSolCD39, pIL2LTrim1 and pIL2LTrim2 and cultured in T175 flasks (30 mL). 5-day/1x sups were then analyzed via ELISA. As shown in TABLE 5, the ELISA results again indicated lower expression levels for the Trim1 and Trim2 variants.

30 To further characterize the effect of the human IL2 (huIL2) residues on the expression of solCD39, the pIL2LSolCD39, pIL2LTrim1, and pIL2LTrim2 products were purified using anti-CD39 coated sepharose. The N-terminal amino acid sequence was determined for each of the purified polypeptides. For solCD39 the N-terminus was APTSSSTKKT. . . (residues 25-34 of SEQ ID NO:11). For Trim1 the N-terminus was ATQNKALPEN. . . (residues 25-34 of SEQ ID NO:27). The Trim2 polypeptides had heterogeneous N-termini.

TABLE 5  
SolCD39 Expression in CM from pIL2LSolCD39 and Trim Transfectants

Sample	[CD39] µg/mL
pIL2LSolCD39	0.796
pIL2LTrim1	0.143
pIL2LTrim2	0.113

35



**B. Preparation and Characterization of Trim3 and Trim4 Variants**

Nucleic acids encoding additional solCD39 variants, designated pIL2LTrim3 ("Trim3") and pIL2LTrim4 ("Trim4"), are also constructed using a synthetic oligo cassette strategy. The N-terminal portions of the solCD39, Trim3 and Trim4 polypeptides are compared below. The predicted cleavage points are indicated as \*.

5 pIL2LSolCD39 MALWIDRMQLLSCIALSLALVTNS\*APTSSST KKTQLtssTQNK...  
(SEQ ID NO:11)

10 pIL2LTrim3 MALWIDRMQLLSCIALSLALVTNS\*A ST KKTQLtssTQNK...  
(SEQ ID NO:28)

pIL2LTrim4 MALWIDRMQLLSCIALSLALVTNS ST\*KKTQLtssTQNK...  
(SEQ ID NO:29)

The polypeptide encoded by the Trim3 construct has the sequence SEQ ID NO:28. Residues 15 36-474 are a soluble portion of CD39 and the predicted cleavage of the leader sequence is between Ser24 and Ala25. The polypeptide encoded by the Trim4 construct has the sequence SEQ ID NO:29. Residues 35-473 are a soluble portion of CD39 and the predicted cleavage of the leader sequence is between Thr26 and Lys27.

The pIL2LTrim3, and pIL2LTrim4 polypeptides are expressed and purified using anti-CD39 20 coated sepharose. The N-terminal amino acid sequence and specific activity are determined for each of the polypeptides.

**C. Preparation and Characterization of solCD39-L4 Fusion Polypeptides**

The CD39 gene family is reported to contain at least four human members: CD39, CD39L2, 25 CD39L3, and CD39L4 (Chadwick and Frischauf, *Genomics* 50:357, 1998). CD39-L4 is reported to be a secreted apyrase (Mulero et al., *J. Biol. Chem.* 274(29):20064, 1999). Additional solCD39 variants are constructed by fusing N-terminal sequences from CD39L2, CD39L3, or CD39L4 to a soluble portion of CD39. The N-terminal amino acid sequences of human CD39 and human CD39-L4 are aligned in Fig. 24.

30 For one construct, CD39-L4-1, a nucleic acid encoding CD39-L4 amino acid residues 1-37 (Met1 to Ser37 of SEQ ID NO:31) is fused to a nucleic acid encoding CD39 residues 38-476 (Thr38 to Thr476 of SEQ ID NO:2). The polypeptide encoded by the CD39-L4-1 construct has the sequence SEQ ID NO:3. Residues 1-37 are from CD39-L4, residues 38-476 are a soluble portion of CD39, and the predicted site of cleavage of the leader sequence is between Ala20 and Val21.

35 For another construct, CD39-L4-2, a nucleic acid encoding CD39-L4 amino acid residues 1-48 (Met1 to Leu48 of SEQ ID NO:31) is fused to a nucleic acid encoding CD39 residues 49-476 (Tyr49 to Thr476 of SEQ ID NO:2). Another construct, CD39-L4-3, is identical to CD39-L4-2 except that the Cys residue at position 39 (Cys39) is replaced by another amino acid, preferably Ser. The polypeptides encoded by the CD39-L4-2 and CD39-L4-3 constructs have the sequence SEQ ID NO:4.

Residues 1-48 are from CD39-L4, residues 49-476 are a soluble portion of CD39, and the predicted site of cleavage of the leader sequence is between Ala20 and Val21.

Additional constructs are constructed by fusing a portion of the CD39-L4 N-terminal coding region to the CD39 N-terminal coding region. After expression in recombinant cells, the N-terminal sequence, enzymatic activity, and platelet inhibitory activity is determined for each of the polypeptide products.

#### D. Preparation and Characterization of IgkappaLsolCD39

Nucleic acids encoding an Igkappa leader sequence fused to amino acids from IL-2 and to solCD39 are also constructed. One such construct encodes a polypeptide having an Igkappa leader and four amino acids from IL-2 fused to the N-terminus of the CD39 soluble portion (set forth as residues Thr38 to Thr476 of SEQ ID NO:2). The N-terminus of the encoded polypeptide is therefore: 5'-METDLLLLWVLLLVPGSTG\*APTSTQNKALPE . . . (amino acids 1-32 of SEQ ID NO:30), where amino acids Met1-Gly20 are the Igkappa leader, Ala21-Ser24 are from IL-2, and Thr25-Glu32 is the beginning of solCD39 sequences. The predicted cleavage site is indicated as \*. The polypeptide encoded by the IgkappaLsolCD39 construct has the sequence SEQ ID NO:30. Residues 25-463 are a soluble portion of CD39 and the predicted cleavage of the leader sequence is between Gly20 and Ala21. After expression in recombinant cells, the N-terminal sequence, enzymatic activity, and platelet inhibitory activity is determined for each polypeptide product.

### EXAMPLE 12

#### Development of a Stably Transfected Cell Line Secreting solCD39

A CHO cell line expressing solCD39 was generated to improve recombinant solCD39 polypeptide production.

#### A. Preparation of Constructs and Cell Lines for the Stable Expression of Soluble CD39 Polypeptides

The solCD39 cDNA insert, containing the recombinant solCD39 sequence and the IL-2 leader but not the FLAG<sup>®</sup> sequence, was excised from the pIL2LsolCD39 plasmid by XmaI/BglIII digestion, then inserted into 2A5Ib, an expression vector containing the DHFR gene and optimized for stable CHO cell lines (Morris et al., *In Animal Cell Technology: From Vaccines to Genetic Medicine*, M.J.T. Carrondo, B. Griffiths, and J.L.P. Moreira, editors, Kluwer Academic Publishers, Boston. 529-534, 1997).

The solCD39-2A5Ib plasmid was transfected into CHO cells using Lipofectamine (GIBCO BRL; Gaithersburg, MD) according to manufacturer's recommendations. The CHO cell line used in these studies, DX B-11, had been adapted to serum-free suspension culture conditions. Transfected cells were grown in modified DMEM-F12 medium, supplemented with peptone, glutamine, glucose, transferrin, lipids, and IGF-1 (insulin-like growth factor 1; used solely when cultures were induced for protein expression). After 3 days growth, the cells were transferred to selective medium lacking

hypoxanthine and thymidine. Stock cultures were grown at 37°C in suspension, and passaged every 2-3 days. Induction cultures were grown at 31°C in suspension, with IGF-1 and sodium butyrate (1-2 mM). Cell density at start of induction cultures was  $1.5-2 \times 10^6$  cells/ml. The average induction period was 7 days, at which time CM was collected for further analyses.

5

#### B. TLC Assays for ADPase and ATPase Activities in CM Containing solCD39

Following growth in selective medium, CM from CHO cell cultures was analyzed for ATPase and ADPase activities. ADPase assays (Marcus et al., *J. Clin. Invest.* 88:1690, 1991) were primarily used in determining enzyme kinetics and pharmacokinetics. Test samples were incubated with 50  $\mu$ M [ $^{14}$ C] ADP (NEN Life Science Products) in assay buffer (15 mM Tris, 134 mM NaCl, 5 mM glucose, pH 7.4, containing 10  $\mu$ M Ap5A ( $P^1, P^5$ -di[adenosine-5']pentaphosphate, 1 mM ouabain, 10  $\mu$ M dipyrindamole, and 3 mM  $CaCl_2$ ) in a total volume of 50  $\mu$ l (5 min, 37°C). Reactions were stopped by placement on ice and addition of 10  $\mu$ l "stop solution" (160 mM disodium EDTA, pH 7.0, 17 mM ADP, 0.15 M NaCl) to block further metabolism of ADP. Nucleotides, nucleosides, and bases were separated by TLC using isobutanol/1-pentanol/ethylene glycol monoethyl ether/ $NH_4OH/H_2O$  (90: 60: 180: 90: 120). Radioactivity was quantified by radio TLC scanning (RTLc multiscanner, Packard, Meriden, CT). Results were calculated as averages of duplicate to quadruplicate measurements after subtraction of buffer blanks (consistently <1% of total radioactivity). Data were expressed as percentage of ADP metabolized or as pmol ADP metabolized per minute per  $\mu$ l CM. A unit of activity is the quantity of enzyme which will degrade 1  $\mu$ mol of ADP in 1 min at 37°C. Identical assays were performed using ATP as a substrate in order to examine the kinetics of the ATPase activity of CD39.

10

15

20

As shown in TABLE 6, the stably transfected CHO cells secreted 20-fold higher levels of both enzyme activities compared to CM from transfected COS-1 cells.

25

TABLE 6  
Comparison of ADPase and ATPase Activities in CM Containing solCD39

Cell Type	ADPase (pmol/min/ $\mu$ l)	ATPase (pmol/min/ $\mu$ l)
CD39 (CHO)	1403	970
CD39 (COS-1)	70	44

#### C. Affinity Purification of solCD39 from Stably Transfected CHO Cells

Thirty ml of 10-fold concentrated CM from solCD39-secreting CHO cells was added to 3 ml of B73 mAb-coated Sepharose 4B gel slurry and mixed overnight at 4°C. The affinity matrix was pelleted by centrifugation, washed 3 times with PBS, and added to a plastic column. Specifically-bound protein was eluted by the addition of 0.1 M triethylamine, pH 11.5. Fractions (1.2 ml each) were collected in tubes containing 120  $\mu$ l of neutralizing solution (1 M sodium phosphate, monobasic; pH 4.3) and analyzed for protein content by SDS-PAGE, followed by Coomassie Blue staining.

30

35

Biological activity was determined using an ATPase assay as described in Example 7, so that peak fractions could be pooled, buffer exchanged into PBS, and concentrated 5-fold. N-linked sugars were removed from purified protein using a kit from Oxford Glycosystems (Rosedale, NY). The recombinant solCD39 was analyzed by SDS-PAGE.

5 A prominent band of ~66 kD was present in early eluted fractions, with a peak of Coomassie Blue staining around fraction 5 (Fig. 5A). Over 90% of the protein present was found as this major band. Overloading the polyacrylamide gel did reveal some smaller molecular weight contaminants, however, these appear to be related to the antibodies present on the column and not to the protein loaded on the column.

10 ATPDase activity of the affinity column fractions correlated with the intensity of protein bands on SDS-PAGE (Fig. 5A, 5B). ATPDase activity was barely detectable in the anti-CD39 column flowthrough, indicating that affinity purification is an effective means of isolating biologically active recombinant solCD39. Treatment of the purified protein with N-glycanase for 18 hours to remove N-linked oligosaccharides caused the broad band of protein at 66 kD to resolve into a much  
15 tighter band of protein at approximately 52 kD, the predicted size for solCD39 (Fig. 5C).

The total protein yield from 1 L of CHO-solCD39 CM was ~2 mg. Production of solCD39 was scaled up to 10 liter bioreactors. The resultant conditioned medium contained approximately 50-100 µg/ml of solCD39 according to ELISA analysis. Thus, each 10 L bioreactor run would expected to produce 500-1000 mg of recombinant polypeptide. CHO cell lines expressing additional solCD39  
20 constructs are similarly prepared and characterized.

### EXAMPLE 13

#### Expression of solCD39 in Veggie-CHO and CS-9 Cells

In this example, soluble CD39 is expressed in CHO cells that have been adapted to grow in  
25 suspension in media that does not contain animal proteins (see Rasmussen et al., *Cytotechnology* 28:31, 1998), or in the presence of IGF-1 in the clonal cell line CS-9.

The dihydrofolate reductase-deficient Chinese hamster ovary cell line, DXB11-CHO is commonly used as a host cell for the production of recombinant polypeptides. DXB11-CHO was adapted to grow in suspension. A serum-free host named Veggie-CHO was then generated by  
30 adapting DXB11-CHO cells to growth in serum-free media in the absence of exogenous growth factors such as Transferrin and Insulin-like growth factor (IGF-1). The latter adaptation was achieved by a gradual reduction of serum supplementation in the media and the replacement of serum with low levels of growth factors, IGF-1 and transferrin, in an enriched cell growth media. The suspension adapted serum-free adapted cells were then weaned off these growth factors. The resulting Veggie-  
35 CHO cells maintain vigorous growth and high viability as well as a DHFR-deficient phenotype in media that is serum-free and also free of animal-derived proteins. CS-9 cells were also derived from DXB11-CHO cells. The suspension adapted serum-free adapted cells were adapted to grow in the

absence of transferrin, then individual clones were isolated. The CS-9 clone was chosen for its stable recombinant protein expression.

Veggie-CHO cells and CS-9 cells are used as a host cell line for the stable, high level expression soluble CD39 polypeptides using methods similar to those described in Example 12.

5

#### EXAMPLE 14 Biochemical Properties of Affinity-Purified solCD39

Purified solCD39 material was subjected to N-terminal amino acid sequencing and mass spectroscopy. Quantitative amino acid analysis of peak fractions (3-9) from the affinity column yielded a ratio of amino acid residues consistent with calculated values for human CD39. The N-terminus of the pIL2LsolCD39 product had the following sequence:

10

A P T S S S T K K T Q L t s s T Q . . . (residues 25-41 of SEQ ID NO:11).

15

The first 12 residues represent the mature huIL2 residues; residues 13-15 (tss, lower case) are linker-encoded residues; residues 16,17, etc. (T Q . . .) are solCD39.

20

Using the TLC assay system described in Example 12B, the ADPase activity of the membrane-bound HUVEC ecto-ADPase was determined at different pHs in buffers containing 100 mM bis-trispropane (Sigma, St. Louis, MO). This was compared to the ADPase activity of purified solCD39 at these pHs. Kinetic constants for CD39 metabolism of ATP and ADP were determined by measuring the initial rates of reaction as analyzed in the TLC system. ADP or ATP at 2.5-150  $\mu$ M were incubated separately with  $2 \times 10^{-9}$  M solCD39.

25

As shown in Fig. 6A, the pH optima for the ecto-ADPase on the surface of HUVEC and for affinity-purified recombinant solCD39 ADPase activities were between pH 8 and 8.5. This indicated that recombinant solCD39 would be maximally active under the same physiological conditions as native CD39/ecto-ADPase .

30

Initial rates of ATP and ADP metabolism by recombinant solCD39 were determined as shown in Fig. 6B, and kinetic constants were derived. The  $K_m$  and  $V_{max}$  for ADP were 5.9  $\mu$ M and 72 pmol/min, respectively; for ATP a  $K_m$  of 2.1  $\mu$ M and  $V_{max}$  of 26 pmol/min were determined. The assays were performed with  $2 \times 10^{-9}$  M solCD39, yielding  $k_{cat}$  of 720  $\text{min}^{-1}$  (ADP) and 260  $\text{min}^{-1}$  (ATP). Thus, the specificity constant,  $k_{cat}/K_m$  ( $1.2 \times 10^8 \text{ min}^{-1} \text{ M}^{-1}$ ), was identical for ADP and ATP. The specific activity for purified recombinant solCD39 was 11 U/mg for ADP and 4 U/mg for ATP.

35

#### EXAMPLE 15 Platelet Inhibitory Properties of solCD39

This example shows that recombinant affinity purified solCD39 is effective as an inhibitor of platelet activation and recruitment.

After obtaining informed consent from volunteers, blood was collected via plastic tubing using acid citrate-dextrose (38 mM citric acid; 75 mM sodium citrate; 135 mM glucose) as

anticoagulant. Where indicated, volunteers had ingested 650 mg acetylsalicylic acid (ASA) 18 h prior to blood donation. Platelet-rich plasma (PRP) was prepared with an initial whole blood centrifugation (200g, 15 min, 25°C), and a second centrifugation of the PRP (90 g, 10 min) to eliminate residual erythrocytes and leukocytes. The stock suspension of PRP was maintained at room temperature under 5% CO<sub>2</sub>-air.

#### A. Platelet Aggregation Studies

PRP containing  $1.22 \times 10^8$  platelets was pre-incubated (3 min, 37°C) in an aggregometer cuvette (Lumiaggregometer; Chrono-Log, Havertown, PA) alone or in combination with test samples containing solCD39. Total volumes were adjusted to 300 µl with TSG buffer (Marcus et al., *J. Clin. Invest.* 88:1690, 1991; Marcus et al., *J. Clin. Invest.* 99:1351, 1997). After the 3 min preincubation, platelet agonists (ADP or collagen) were added at the concentrations indicated, and the aggregation response recorded for 4-5 min. Where indicated, 10 µM indomethacin (Sigma, St. Louis, MO) was added to PRP to inhibit endogenous cyclooxygenase activity.

As shown in Fig. 7, the addition of 10 µM ADP to PRP alone resulted in a full, irreversible aggregation response; partially reversible aggregation occurred at lower ADP concentrations. However, in the presence of only 3.3 µg/ml solCD39, platelet aggregation induced by 10 µM ADP was abruptly terminated and the curve rapidly returned to baseline. Importantly, the extent of aggregation was reduced to levels below those observed with 1 µM ADP. Higher concentrations of solCD39 had an even more profound inhibitory effect, virtually eliminating the initial burst of aggregation elicited by 10 µM ADP.

Platelet responsiveness to 5 µM ADP was examined in PRP treated with and without the cyclooxygenase inhibitor indomethacin (10 µM), in the presence of CM containing solCD39 from COS-1 and CHO cells. As shown in Fig. 8A, indomethacin treatment resulted in partial reversal of ADP-induced platelet aggregation in the absence of solCD39. In contrast, CM containing solCD39 were capable of completely abrogating platelet responses to ADP, whether PRP was indomethacin-treated or not.

Inhibition of platelet reactivity by CD39 was not limited to blocking the agonistic effects of ADP, as shown in Fig. 8B and 8C. Collagen, which is another critical platelet agonist, was used at 1 µg/ml to induce platelet aggregation. The presence of solCD39 markedly reduced the response to collagen compared to control (Fig. 8B, upper curves). A similar inhibitory effect of solCD39 was observed in PRP treated with indomethacin (Fig. 8B, lower curves), when collagen was used at 3.3 µg/ml. As shown in Fig. 8C, the effect of solCD39 on collagen-induced aggregation was dose dependent.

#### B. Inactivation of Enzymatic Activity of solCD39 and the Effect on Inhibition of Platelet Activation

To demonstrate that the ability of solCD39 to inhibit platelet activation and recruitment was due to the enzymatic activity of solCD39 and not to some other property, the solCD39 was reacted

with FSBA (Fluorosulfonylbenzoyl-adenosine), an ATP analog that inhibits collagen-induced platelet activation (Colman et al., *Blood* 68:565, 1986) and binds irreversibly with ATPases found on several cell types (Sevigny et al., *Biochem. Biophys. Acta* 1334:73, 1997; Sevigny et al., *Biochem. J.*, 312:351, 1995).

5           SolCD39 (2 nmol) was combined with 2 ml labeling buffer (100 mM Hepes, pH 7.4, 200 mM NaCl, 4% dimethylformamide [vol/vol]), 400  $\mu$ l 5 mM FSBA (Sigma Chemical Co.) dissolved in ethanol, and 1.52 ml water. A mock-treated sample was also prepared in which the FSBA solution was replaced with water. After incubating at 37° for 90 min., the samples were centrifuged in a Centricon-10 filter unit (Amicon Corp.) for 1 hour at 5,500 rpm and buffer exchanged into PBS to  
10 remove unreacted material. The effect of FSBA-treated solCD39 on platelet reactivity is shown in Figure 9.

          Induction of platelet activation by ADP (Fig. 9A) or collagen (Fig. 9B) was significantly inhibited by either purified solCD39 or mock FSBA-treated solCD39. In contrast, incubation with FSBA-treated solCD39 did not have a significant effect on platelet activation. A comparative titration  
15 of mock-treated solCD39 versus FSBA-treated solCD39 (Fig. 9C) indicated that 22.0  $\mu$ g/ml of FSBA-treated sol CD39 gave a similar aggregation profile as 0.88  $\mu$ g/ml of mock-treated solCD39. This indicated that 96% of the aggregation inhibitory activity of solCD39 was lost after FSBA derivitization. Analyses of residual ADPase activity of FSBA- treated solCD39 by the radio-TLC  
20 assay system demonstrated that approx. 94% of the enzymatic activity was blocked, while the phosphate release assay indicated that a similar percentage of the ATPase activity was lost as well.

### C. Mutagenesis Studies

          To identify amino acids involved in the biological activity of solCD39, site directed mutagenesis was used to alter selected amino acid residues in CD39. Mutants were assayed for  
25 enzymatic (ATPase and ADPase) and platelet inhibitory (dose-dependent inhibition of platelet aggregation) activities. For one series of mutants, residues within the conserved apyrase regions were replaced with alanine.

          Platelet inhibitory activity correlated generally with enzymatic activity. The E174A mutant (residues are numbered as in Figure 1) was completely devoid of enzymatic activity and had no effect  
30 on platelet responsiveness; the S218A mutant retained less than 10% of ADPase activity and approx. 10% of platelet inhibitory activity. Glutamate174 and Serine218 therefore appear to be important for both the enzymatic and platelet inhibitory activities of CD39.

          Additional mutant forms of CD39 are expressed and assayed for enzymatic and platelet inhibitory activity in order to identify mutants with increased or decreased activity as well as mutants  
35 that preferentially catalyze the ATPase or ADPase reaction.

**EXAMPLE 16****Persistence of solCD39 Following In Vivo Administration in Mice**

Balb/c mice (6-8 weeks of age; maintained under specific pathogen-free conditions; Jackson Laboratory, Bar Harbor, ME) were intravenously injected with 50 µg recombinant solCD39 in 100 µl sterile saline (0.9% NaCl). No overt external difficulties were noted in the animals following injection. At various times after injection (5, 10, 30 min, 1, 2, 4, 8, 24 h), pairs of mice were bled by cardiac puncture and euthanized. Serum was prepared from each blood sample and frozen until assay. The presence of biologically active solCD39 in serum samples was measured in ATPase and ADPase assays. The data were fit using Deltagraph (Deltapoint, Monterey, CA). The best fit was derived using double exponential decay. Where indicated, specificity of enzyme activity was determined by incubating serum samples with anti-CD39 mAb-coated beads to remove CD39 prior to testing for ATPase activity.

As shown in Fig. 10, the data obtained best fit a biphasic exponential curve. The amount of ATPase activity from 25 µg/ml of solCD39 placed in murine serum is presented for comparison. The  $t_{1/2\alpha}$  (distribution phase) was calculated to be 59 min in the ATPase assay and 43 min in the ADPase assay. Approximately 55-65% of apyrase activity was cleared from the circulation during this phase. The elimination phase had a  $t_{1/2\beta}$  of approximately 40 h in both assays. Preclearing the 10 min, 2h, and 24 h time point samples with anti-CD39 mAb-coated beads completely eliminated serum ATPase/ADPase activities. These data also demonstrate that the assays specifically detect recombinant human solCD39.

**EXAMPLE 17****Pilot Dose Ranging Study in Yorkshire-Hampshire Pigs**

SolCD39 was administered to Yorkshire-Hampshire pigs, which have been developed as a porcine model of thrombosis. Following intravenous injection, CD39 persisted in the circulation and was capable of inhibiting platelet aggregation and recruitment for as much as a week following injection. This is in marked contrast to many other therapeutic agents used for platelet inhibition, wherein the duration of inhibition is very short.

Ten pigs were randomly assigned to receive solCD39 in low (72 µg/kg), medium (221 µg/kg), or high (670 µg/kg) doses. Aspirin was administered orally on a daily basis. Placebo controls consisted of aspirin. Saline controls and solCD39 were administered as a single bolus. Time points were measured following this administration. Blood samples were obtained via an external jugular vein catheter. Bleeding times were measured in pigs receiving placebo controls and in those receiving solCD39 at baseline and at 60 minutes. ADP-induced platelet aggregation was measured at specific time intervals following administration. The concentration of CD39 in serum as a function of time was measured using an ELISA assay.

Administration of solCD39 was well tolerated. It did not induce anemia or thrombocytopenia and, importantly, a second dose of solCD39 could be administered without observable ill effects, such



as hypotension, thrombocytopenia, or hemorrhage. Clot retraction was normal following all experiments, indicating that platelet function was essentially normal.

#### A. Effect of solCD39 on Bleeding Time

- 5           Bleeding time is an absolute measure of platelet function. As shown in Figure 11, solCD39 induced a prolonged bleeding time. This indicated that a therapeutic effect had been obtained via a mild interference with platelet function. These mild increases in bleeding time were similar to those obtained by aspirin administration. This indicates that the hemorrhagic defect was mild.

#### 10   B. Effects of Aspirin and solCD39 on Platelet Aggregation

- Figure 12A shows the effect of aspirin on platelet aggregation at baseline and at day 5, and Figure 12B shows the effect of high dose solCD39 on platelet aggregation at baseline and at day 7. Peak heights from the platelet aggregation curves for each of the three solCD39 doses are plotted in Fig. 13. The platelet aggregation data are also compared by plotting relative areas from the platelet aggregation curves for each of the three solCD39 doses. A dose of 670  $\mu\text{g}/\text{kg}$  inhibited greater than 90% of ADP induced platelet aggregation. The inhibitory effect was long-lived, with 30% inhibition (after high dose solCD39) at two weeks. These experiments show that solCD39 has potent and long lasting anti-platelet effects, and that these effects are superior to those obtained using aspirin.

#### 20   C. Persistence of solCD39 in Serum

- The persistence of solCD39 in porcine serum, as determined by ELISA, is shown in Fig. 14. Distribution and clearance half-lives were determined using a biphasic curve fit. The  $t_{1/2\alpha}$  (distribution phase) was calculated to be 29 minutes. The elimination phase had a  $t_{1/2\beta}$  of approximately 51 hours. SolCD39 biological activity (ADPase activity) also exhibited a long elimination half-life, approaching 25 5-7 days, and could still be detected over two weeks after administration. During this time there were no changes in hematologic parameters and no evidence of hemorrhage despite tripling of the bleeding time.

#### D. Percutaneous Transluminal Coronary Angioplasty (PTCA) Study

- 30           Porcine platelets and fibrinogen were labeled with  $^{111}\text{Indium}$  and  $^{125}\text{Iodine}$  respectively for infusion into pigs. Twelve pigs were sedated and anesthetized, and randomly assigned to receive intravenous solCD39 (670  $\mu\text{g}/\text{kg}$ ) plus heparin and ASA or intravenous saline placebo plus heparin and ASA. Oral ASA was given to all pigs for at least three day prior to the coronary angioplasty procedure, and heparin (100 U/kg) was given at the time of the angioplasty. One to three days prior to 35 the angioplasty an external jugular line was inserted to administer the labeled platelets and fibrin, CD39 or saline, and to facilitate blood draws. Labeled platelets and fibrinogen were given approximately 18 hours prior to balloon injury. Coronary arteries were injured using an oversize

balloon. A coronary guide catheter was first advanced into the ascending aorta. An oversized balloon was then advanced into a coronary vessel and inflated at 6 to 8 atmospheres for a total of thirty seconds. The balloon was then deflated and withdrawn. The average ratio of balloon size to vessel size was 1.32 for the placebo group and 1.29 for the CD39 group.

5 Platelet aggregation and bleeding time were measured 30 minutes after administration. The pigs were killed 24 hours after balloon injury and solCD39 administration, and the labeled platelet ( $^{111}\text{Indium}$ ) and fibrin ( $^{125}\text{Iodine}$ ) deposition per  $\text{cm}^2$  was measured in the injured coronary artery segments. The results are summarized in TABLE 7. CD39 administration was well tolerated without  
 10 bleeding or hemodynamic complications. Moreover, no bleeding was noted during PTCA or after sheath removal and there was no significant difference in hematocrit or platelet counts between the groups.

These results show that the administration of solCD39 results in a significant inhibition of platelet aggregation and prolongation of bleeding time, as well as a trend toward inhibition of platelet and fibrin deposition, after balloon injury in animals. The results also suggest that CD 39 has a  
 15 minimal risk of inducing bleeding.

TABLE 7  
Effects of solCD39 After Balloon Injury

Treatment	Platelet Deposition Ratio	Fibrin Deposition Ratio	Bleeding Time	% Inhibition of Platelet Aggregation
Placebo	$1.78 \pm 0.4$	$0.71 \pm 0.14$	$3.03 \pm 0.2$	$1 \pm 10$
solCD39	$1.25 \pm 0.19$	$0.62 \pm 0.10$	$7.00 \pm 0.81$	$80 \pm 2$
p-value	0.2	0.5	0.009	0.001

After the radioactivity decayed, toluidine-blue stained injured coronary artery segments were  
 20 examined histologically, in order to further characterize the extent of thrombus formation. A blinded observer qualitatively evaluated the degree of histologic injury in the coronary segments by assessing, on a scale of 1-4 with 4 being the most severe injury, the severity of medial and internal elastic lamina tear, medial separation, and hemorrhage. A composite injury score was obtained by totaling the three individual scores. The medial injury scores for the placebo and CD39 groups were 2.5 and 2.2  
 25 respectively; medial separation scores for the placebo and CD39 groups were 2.0 and 1.6 respectively; the degree of hemorrhage for the placebo and CD39 groups were 2.3 and 2.5 respectively. The composite injury scores for the placebo and CD39 groups were 6.6 and 6.2 respectively. These in vivo results correlate well with results, reported herein, obtained in vitro and ex vivo.

30

**EXAMPLE 18**  
**Soluble CD39 Provides Additive Inhibition of Platelet Aggregation Over Aspirin and Abciximab**

An ex vivo study was performed in order to evaluate the additive inhibition of platelet aggregation when soluble CD39 is added to platelet rich plasma from patients receiving: placebo,

aspirin, clopidogrel, ticlopidine, or abciximab. Each group consisted of three to six patients. The clopidogrel, ticlopidine, and abciximab groups also received aspirin. Baseline platelet aggregation was measured for each group, in response to the platelet agonists ADP, collagen, or the Thrombin Receptor Activating Peptide TRAP<sub>1-6</sub>. SolCD39 (10 µg/ml or 100 µg/ml) was then added and the additional inhibition of platelet activation (over baseline, in response to the platelet agonists) was measured in each of the five groups. The result are shown in TABLE 8.

TABLE 8  
Additive Inhibition of Platelet Aggregation by Soluble CD39

	Group				
	Placebo	Aspirin	Clopidogrel	Ticlopidine	Abciximab
Baseline					
ADP	84 ± 4 <sup>1</sup>	69 ± 5	58 ± 6	76 ± 3	0 ± 0
Collagen	85 ± 1	62 ± 8	57 ± 9	71 ± 17	0 ± 0
TRAP	94 ± 2	66 ± 6	51 ± 2	26 ± 5	46 ± 6
SolCD39 10 µg/ml					
ADP	0 ± 0 100% <sup>2</sup>	4 ± 2 97%	5 ± 2 92%	10 ± 2 86%	0 ± 0 100%
Collagen	75 ± 2 11%	21 ± 4 68%	31 ± 9 48%	48 ± 18 37%	0 ± 0 100%
TRAP	70 ± 3 26%	38 ± 7 45%	35 ± 1 31%	19 ± 6 33%	22 ± 10 52%
SolCD39 100 µg/ml					
ADP	0 ± 0 100%	1 ± 0 99%	0 ± 0 100%	2 ± 2 97%	0 ± 0 100%
Collagen	57 ± 5 33%	16 ± 4 75%	21 ± 6 64%	37 ± 15 53%	0 ± 0 100%
TRAP	65 ± 4 30%	26 ± 5 63%	23 ± 3 55%	18 ± 7 36%	22 ± 9 52%

<sup>1</sup>Platelet aggregation, arbitrary units

<sup>2</sup>Percent inhibition relative to same agonist in the absence of CD39

Soluble CD39 at a concentration of 10 µg/ml synergistically inhibited ADP, collagen, and TRAP mediated platelet aggregation in patients on aspirin ( $p < 0.001$ ), and this effect was independent of clopidogrel and ticlopidine. Abciximab alone abolished platelet aggregation due to ADP and collagen, but CD39 provided synergistic inhibition of platelet aggregation induced by TRAP ( $p < 0.007$ ). Soluble CD39 at 100 µg/ml provided increased inhibition of platelet aggregation to all agonists. These results were also seen in vitro. Collagen and TRAP induce platelet aggregation via mechanisms in addition to ADP release and recruitment, so the ability of CD39 to inhibit collagen and TRAP-mediated platelet aggregation suggests additional versatility of CD39 as an antithrombotic agent.

## EXAMPLE 19

Soluble CD39 Inhibits Thrombosis and Limits Ischemic Cerebral Injury  
in Wild Type and Reconstituted CD39 Null Mice

5 The above examples suggested that soluble CD39 would inhibit ADP-mediated amplification  
of platelet recruitment in distal microvessels, thereby reducing thrombosis after stroke. The following  
experiments illustrate the use of CD39 in a microvascular thrombosis (murine ischemic stroke) model.  
Soluble CD39 inhibited microvascular thrombosis and conferred cerebroprotection in stroke. A  
notable feature of the solCD39 treatment was the low incidence of intracerebral hemorrhage relative to  
that reported for other antithrombotic agents.

10

A. Materials and Methods

C57BL/6J mice (6-8 wk) were obtained from Jackson Laboratories (Bar Harbor, ME).  
Untreated mice, and mice treated with 4 mg/kg solCD39, with 5 mg/kg aspirin or phosphate buffered  
saline, were anesthetized and heparinized (10 U/g), prior to blood collection via cardiac puncture. 80  
15  $\mu\text{L}$  of 3.8% trisodium citrate was added to each mL of blood. Samples from 6-8 mice were pooled and  
platelet-rich plasma (PRP) was prepared by centrifugation. The PRP contained  $400\text{-}700 \times 10^3$   
platelets per  $\mu\text{L}$ . All experiments were completed within 2 hours of blood collection. PRP (200  $\mu\text{L}$ )  
was preincubated, for 3 min. at  $37^\circ\text{C}$ , with 100  $\mu\text{L}$  Tris-buffered saline buffer (15 mM NaCl, 5 mM  
glucose, pH 7.4) in an aggregometer cuvette (Lumiaggregometer; Chrono-Log, Havertown, PA), and  
20 the platelet agonists ADP, collagen, or sodium arachidonate were added at the final concentrations  
indicated. Aggregation responses were recorded for 2-4 min, and expressed as area under the curve  
(height times width at 1/2 height).

The effects of soluble CD39 were tested in a previously validated murine model of stroke  
injury (Choudhri, T.F., et al., *J. Clin. Invest.* 102:1301-1310 (1998); Connolly, E.S., Jr., et al., *J. Clin.*  
25 *Invest.* 97:209-216 (1996); and Connolly, E.S., Jr., et al., *Neurosurg.* 38(3):523-532 (1996)).  
Anesthetized mice were maintained at  $37 \pm 2^\circ\text{C}$  during and for 90 min following surgery. A midline  
neck incision was made and the right carotid artery exposed. Middle cerebral artery occlusion was  
accomplished by advancing a 13-mm heat-blunt tipped 6-0 nylon suture via an arteriotomy in the  
external carotid stump. The external carotid artery was cauterized to secure hemostasis, and arterial  
30 flow re-established. Carotid artery occlusion never exceed 3 min. The occluding suture was removed  
after 45 min and cautery was again locally applied to prevent bleeding at the arteriotomy site. Surgical  
staples were used for wound closure.

Doppler measurement of cerebral cortical blood flow, neurological score (Huang, Z., et al.,  
*Science* 265:183-1885 (1994)), calculation of infarct volume, measurement of cerebral thrombosis  
35 using  $^{111}\text{In}$ -labeled platelets (Choudhri, T.F., et al., *J. Clin. Invest.* 102:1301-1310 (1998) and Naka,  
Y., et al., *Circ. Res.* 76:900-906 (1995)), detection of intracerebral fibrin (Choudhri, T.F., et al., *J.*  
*Clin. Invest.* 102:1301-1310 (1998)), and measurement of intracerebral hemorrhage (Choudhri, T.F., et

al., *J. Clin. Invest.* 102:1301-1310 (1998) and Choudhri, T.F., et al., *Stroke* 28:2296-2302 (1997)) were measured as previously described. The results are described below.

#### B. Soluble CD39 Abrogates the Ex Vivo Aggregation of Murine Platelets

5 Platelet-rich plasma was obtained from mice 1 hour after injection of saline (vehicle), soluble CD39, or aspirin. Ex vivo platelet aggregation was studied to ascertain the relative potency of solCD39 as compared to aspirin (which can improve the outcome following a transient ischemic attack). Platelets from control and aspirin-treated mice strongly aggregated following stimulation with ADP (Fig. 15A) or collagen (Fig. 15B).

10 Soluble CD39 abrogated platelet aggregation in the presence of ADP, and attenuated aggregation in the presence of collagen and arachidonate. In contrast, aspirin treatment only blocked platelet reactivity to arachidonate (Fig. 15C). The platelets from mice pretreated with solCD39 showed an initial aggregation in the presence of arachidonate, but rapidly disaggregated and returned to the resting state before a full response occurred (Fig. 15C).

15

#### C. Soluble CD39 Is Effective Even When Added at the Peak of the Aggregation Response

ADP (5  $\mu$ M) was added to mouse platelets in vitro to induce an aggregation response. Soluble CD39 (2.5  $\mu$ g/ml or 1.25  $\mu$ g/ml) was added at the peak of the aggregation response. The solCD39 immediately reversed the aggregation response, as shown in Fig. 16. This result demonstrates that SolCD39 is able to reverse an aggregation response, rapidly returning platelets to a resting state, even when added at the peak of the response. This result likely reflects the fact that at the peak of the aggregation response ADP is prominent in the releasate from the aggregating platelets. Soluble CD39 metabolizes this ADP to the biologically inactive compound AMP almost instantaneously, accounting for the rapid descent of the aggregation curve in Fig. 16, right side.

25

#### D. Soluble CD39 Reduces the Sequelae of Stroke

Intravenously injected soluble CD39 showed therapeutic utility in stroke. Soluble CD39 inhibited platelet accumulation in the ipsilateral cerebral hemisphere following induction of stroke, as shown in Fig. 17A. Similarly, solCD39 decreased the level of fibrin accumulation in the ipsilateral hemisphere (vs. contralateral) as measured by Western blot analysis using a fibrin specific antibody (Fig. 17B).

The ability of solCD39 to reduce thrombosis, as measured by decreased platelet and fibrin deposition, was accompanied by improved postischemic cerebral perfusion 24 hours after stroke induction, as shown in Fig. 18A. In contrast, when aspirin was administered at a clinically relevant dose (that inhibited the ex vivo response of platelets to arachidonate) no improvement was seen in postischemic cerebral blood flow (Fig. 18A).

35 Preoperatively administered solCD39 conferred a dose-dependent diminution of cerebral infarct volume, as measured by digital histological analysis (Fig. 18B). Aspirin, in contrast, showed a

tendency to decrease cerebral infarct volume, although this effect was not statistically significant. The administration of soluble CD39 either prior to, or up to 3 h following, stroke reduced both neurological deficit (Fig. 18C) and mortality (Fig. 18D).

The effects of soluble CD39 and aspirin on the development of intracerebral hemorrhage following stroke are shown in Fig. 18E. Aspirin increased intracerebral hemorrhage (as measured spectrophotometrically) significantly, but there was no significant increase in intracerebral hemorrhage at any dose of soluble CD39 tested. At these doses, soluble CD39 inhibited both platelet and fibrin accumulation and promoted an increase in postischemic blood flow, as shown in Figs. 17A, 17B, and 18A. Figure 19 shows a covariate plot of cerebral infarct volume vs. intracerebral hemorrhage for each treatment, and indicates that aspirin is less capable of reducing infarct volume and preventing intracerebral hemorrhage than soluble CD39. In summary, at the doses tested in the mouse stroke model, solCD39 conferred protection without inducing the bleeding problems that often accompany anti-thrombotic therapy regimens.

#### 15 E. CD39 Null Mice Can be Reconstituted with Soluble CD39

CD39<sup>-/-</sup> mice were generated using a gene targeting vector in which exons 4-6, encoding apyrase conserved regions 2-4 (Handa, M. & Guidotti, G., *Biochem. Biophys. Res. Commun.* 218:916-923 (1996); Wang, T.F. & Guidotti, G., *J. Biol. Chem.* 271:9898-9901 (1996); Maliszewski, C.R., et al., *J. Immunol.* 153:3574-3583 (1994); and Schoenborn, M.A., et al., *Cytogen Cell Gen.* 81(3-4):287-280 (1998)), were replaced with a PGKneo cassette, as shown in Fig. 20A. The gene targeting vector, in which a 4.1 kb *SpeI-BglIII* fragment containing exons 4-6 was replaced with a PGKneo cassette, was introduced into 129-derived ES cells. Cells were selected in G418 and gancyclovir. Nine ES clones with a disrupted CD39 allele, as identified by genomic Southern blot analyses of *BglIII* digested DNA as shown in Fig. 20B, were injected into blastocysts and the resulting chimeras crossed to C57BL/6 to produce CD39 +/- heterozygotes. CD39<sup>-/-</sup> mice were generated at the expected Mendelian frequency from CD39 +/- intercrosses. The CD39<sup>-/-</sup> mice used in the experiments described below represent random C57BL/6 x 129 hybrids.

Homozygous CD39<sup>-/-</sup> mice were overtly normal, and did not display an obvious phenotype in the unperturbed state. Hematological profiles, including erythrocyte parameters, platelet counts, leukocyte counts and differentials, and coagulation screening, were normal. As shown below, the CD39-null mice did not exhibit a prothrombotic phenotype unless challenged by experimental stroke. Under those conditions, the defect was abolished and normal blood fluidity was restored by administration of soluble CD39. Bleeding times of CD39<sup>-/-</sup> mice were normal, indicating that normal blood flow in an unperturbed animal is not dependent upon endogenous expression of CD39. As is seen in normal mice, CD39<sup>-/-</sup> animals exhibited markedly increased bleeding times following the administration of aspirin or following administration of increasing doses of solCD39 as shown in Fig. 21. CD39<sup>-/-</sup> mice subjected to focal cerebral ischemia exhibited diminished blood flow following reperfusion as compared to genetically matched controls (Fig. 22A), indicating that endogenous CD39

contributes to maintenance of hemostasis during episodes of vascular injury. When solCD39 (8 mg/kg) was administered to the CD39<sup>-/-</sup> mice, these mice were "reconstituted" as shown by a postischemic blood flow similar to untreated controls. CD39<sup>-/-</sup> mice demonstrated increased cerebral infarction volume as compared to genotype-matched controls following induced stroke (Fig. 22B).  
5 CD39<sup>-/-</sup> mice "reconstituted" with solCD39 had markedly diminished infarct volume, indicating a protective effect of solCD39. Other parameters (neurological deficit scores, overall mortality, and intracerebral hemorrhage) did not differ between groups (Fig. 22 C, D, E).

These results demonstrate that CD39 inhibits microvascular thrombosis and confers cerebroprotection without inducing intracerebral hemorrhage in a murine model of stroke. Soluble  
10 CD39 decreased platelet deposition, fibrin deposition, and cerebral infarction volume. Soluble CD39 reduced infarction volume and restored postischemic blood flow even when administered three hours following stroke induction. This result is important because the average patient experiencing a stroke appears in the emergency room approximately three hours after the initial event occurs. The ability to treat patients with solCD39 after three hours provides an important advantage over many other agents  
15 designed to inhibit platelet reactivity.

#### EXAMPLE 20

##### Soluble CD39 Improves Survival in a Mouse Ischemia Model

C57BL/6 mice were anesthetized and ventilated, and their thoraces were opened to surgically  
20 expose both pulmonary hila. Either physiological saline or soluble CD39 (8 mg/kg) was administered intravenously, after which the left pulmonary hilum was cross-clamped for one hour. The cross-clamp was removed for three hours of reperfusion, and then a cross-clamp was applied to the right hilum for a thirty minute observation period. This latter maneuver effectively removed the normal lung from circulation, so that the mouse must survive on the function of the post-ischemic left lung. The results  
25 are shown, in the form of a Kaplan-Meier survival plot, in Figure 23. All of the mice given saline (n=6) died prior to the thirty minute time point whereas all of the sol39-treated mice (n=3) survived for thirty minutes.

The long lasting effects of soluble CD39 are also shown to be clinically useful in the reduction of complications of atherosclerosis, such as myocardial infarction, stroke, and peripheral  
30 vascular occlusion. Patients suffering from these conditions demonstrate an abundance of activated platelets in their circulation, and such activated platelets have a lowered threshold for ADP stimulation. Soluble CD39 metabolically deletes ADP from the fluid phase of activated platelets and reverses their prothrombotic characteristics.

The relevant disclosures of publications cited herein are specifically incorporated by  
35 reference. The examples presented above are not intended to be exhaustive or to limit the scope of the invention. The skilled artisan will understand that variations and modifications and variations are possible in light of the above teachings, and such modifications and variations are intended to be within the scope of the invention.

CLAIMS

We claim:

1. A soluble CD39 polypeptide selected from the group consisting of:
  - (a) polypeptides having an amino acid sequence as set forth in Figure 1 (SEQ ID NO:2) wherein the amino terminus is selected from the group consisting of amino acids 36-44, and the carboxy terminus is selected from the group consisting of amino acids 471-478;
  - (b) fragments of the polypeptides of (a) wherein said fragments have apyrase activity;
  - (c) variants of the polypeptides of (a) or (b), wherein said variants have apyrase activity; and
  - (d) fusion polypeptides comprising the polypeptides of (a), (b), or (c), wherein said fusion polypeptides have apyrase activity.
  
2. A soluble CD39 polypeptide according to claim 1 selected from the group consisting of:
  - (a) polypeptides having a sequence consisting of amino acids 38-476 or 39-476 of SEQ ID NO:2;
  - (b) variant polypeptides that are at least 70% identical in amino acid sequence to amino acids 36 to 478 of SEQ ID NO:2 or to a fragment thereof, wherein said variant polypeptides have apyrase activity;
  - (c) variant polypeptides that are at least 80% identical in amino acid sequence to amino acids 36 to 478 of SEQ ID NO:2 or to a fragment thereof, wherein said variant polypeptides have apyrase activity;
  - (d) variant polypeptides that are at least 90% identical in amino acid sequence to amino acids 36 to 478 of SEQ ID NO:2 or to a fragment thereof, wherein said variant polypeptides have apyrase activity;
  - (e) variant polypeptides that are at least 95% identical in amino acid sequence to amino acids 36 to 478 of SEQ ID NO:2 or to a fragment thereof, wherein said variant polypeptides have apyrase activity;
  - (f) variant polypeptides that are at least 98% identical in amino acid sequence to amino acids 36 to 478 of SEQ ID NO:2 or to a fragment thereof, wherein said variant polypeptides have apyrase activity; and
  - (g) variant polypeptides that are at least 99% identical in amino acid sequence to amino acids 36 to 478 of SEQ ID NO:2 or to a fragment thereof, wherein said variant polypeptides have apyrase activity.
  
3. A polypeptide having the structure X-Y wherein Y is the soluble CD39 polypeptide of claim 1 and X is selected from the group consisting of an Ala residue and peptides capable of adopting a stable secondary structure.



4. The polypeptide of claim 3 wherein X is a peptide fragment from the amino terminal portion of mature IL-2, CD39-L2, CD39-L3, or CD39-L4.

5. A polypeptide having the structure A-B-C wherein A is 0-20 amino acids from the amino terminal portion of mature IL-2, B is a linker of 0-15 amino acids, and C is the soluble CD39 polypeptide of claim 1.

6. A soluble CD39 polypeptide selected from the group consisting of:

(a) SEQ ID NO: 6, amino acids 25-464 of SEQ ID NO:27, amino acids 25-474 of SEQ ID NO:28, amino acids 27-473 of SEQ ID NO:29, amino acids 21-476 of SEQ ID NO:3, amino acids 21-476 of SEQ ID NO:4, or amino acids 21-463 of SEQ ID NO:30;

(b) fragments of the polypeptides of (a) wherein said fragments have apyrase activity;

(c) variants of the polypeptides of (a) or (b), wherein said variants have apyrase activity; and

(d) fusion polypeptides comprising the polypeptides of (a), (b), or (c), wherein said fusion polypeptides have apyrase activity.

7. A polypeptide selected from the group consisting of:

(a) variant polypeptides that are at least 70% identical in amino acid sequence to the soluble CD39 polypeptide of claim 6, wherein said variant polypeptides have apyrase activity;

(d) variant polypeptides that are at least 80% identical in amino acid sequence to the soluble CD39 polypeptide of claim 6, wherein said variant polypeptides have apyrase activity;

(e) variant polypeptides that are at least 90% identical in amino acid sequence to the soluble CD39 polypeptide of claim 6, wherein said variant polypeptides have apyrase activity;

(f) variant polypeptides that are at least 95% identical in amino acid sequence to the soluble CD39 polypeptide of claim 6, wherein said variant polypeptides have apyrase activity;

(g) variant polypeptides that are at least 98% identical in amino acid sequence to the soluble CD39 polypeptide of claim 6, wherein said variant polypeptides have apyrase activity; and

(h) variant polypeptides that are at least 99% identical in amino acid sequence to the soluble CD39 polypeptide of claim 6, wherein said variant polypeptides have apyrase activity.

8. The soluble CD39 polypeptide of claim 6 having an amino acid sequence selected from the group consisting of SEQ ID NO: 6, amino acids 25-464 of SEQ ID NO:27, amino acids 25-474 of SEQ ID NO:28, amino acids 27-473 of SEQ ID NO:29, amino acids 21-476 of SEQ ID NO:3, amino acids 21-476 of SEQ ID NO:4, and amino acids 21-463 of SEQ ID NO:30.

9. An isolated nucleic acid encoding a polypeptide of one of claims 1-8.

10. The nucleic acid of claim 9 wherein said nucleic acid is DNA.

11. The DNA of claim 10 having a sequence selected from the group consisting of:

(a) SEQ ID NO:5;

(b) DNA sequences which, due to degeneracy of the genetic code, encode the polypeptide encoded by SEQ ID NO:5;

(c) DNA sequences that hybridize to SEQ ID NO:5 under moderately stringent conditions;

(d) DNA sequences that are at least 70% identical in sequence to SEQ ID NO:5 or to a fragment thereof;

(e) DNA sequences that are at least 80% identical in sequence to SEQ ID NO:5 or to a fragment thereof;

(f) DNA sequences that are at least 90% identical in sequence to SEQ ID NO:5 or to a fragment thereof;

(g) DNA sequences that are at least 95% identical in sequence to SEQ ID NO:5 or to a fragment thereof;

(h) DNA sequences that are at least 98% identical in sequence to SEQ ID NO:5 or to a fragment thereof; and

(i) DNA sequences that are at least 99% identical in sequence to SEQ ID NO:5 or to a fragment thereof.

12. The DNA of claim 10 wherein said DNA further encodes a leader peptide operably linked to the N-terminus of the polypeptide, wherein the leader peptide facilitates the extracellular secretion of the polypeptide.

13. The DNA of claim 12 wherein the leader peptide comprises all or part of a leader from IL-2, proinsulin, human growth hormone (huGH), IL7, or I $\kappa$ gkappa.

14. The DNA of claim 13 wherein the leader peptide comprises the sequence SEQ ID NO:9.

15. The DNA of claim 12 having a sequence selected from the group consisting of

(a) SEQ ID NO:7;

(b) DNA sequences which, due to degeneracy of the genetic code, encode the polypeptide encoded by SEQ ID NO:7;

(c) DNA sequences which hybridize to SEQ ID NO:7 under moderately stringent conditions;

(d) DNA sequences that are at least 70% identical in sequence to SEQ ID NO:7 or to a fragment thereof;

(e) DNA sequences that are at least 80% identical in sequence to SEQ ID NO:7 or to a fragment thereof;

(f) DNA sequences that are at least 90% identical in sequence to SEQ ID NO:7 or to a fragment thereof;

(g) DNA sequences that are at least 95% identical in sequence to SEQ ID NO:7 or to a fragment thereof;

(h) DNA sequences that are at least 98% identical in sequence to SEQ ID NO:7 or to a fragment thereof; and

(i) DNA sequences that are at least 99% identical in sequence to SEQ ID NO:7 or to a fragment thereof.

16. A vector comprising the nucleic acid of claim 9.

17. The vector of claim 16 wherein said vector is an expression vector.

18. The vector of claim 17 wherein said vector is a eukaryotic expression vector.

19. A eukaryotic expression vector comprising the sequence SEQ ID NO:5.

20. A eukaryotic expression vector comprising the sequence SEQ ID NO:7.

21. A recombinant cell comprising the nucleic acid of claim 9.

22. The cell of claim 21 wherein said cell is a prokaryotic cell.

23. The cell of claim 21 wherein said cell is a eukaryotic cell.

24. The cell of claim 23 wherein said cell is a COS cell or a CHO cell.

25. The cell of claim 24 wherein said cell is a CHO cell that has been adapted to grow in suspension and in the absence of serum.

26. A recombinant CHO cell comprising a nucleic acid sequence SEQ ID NO:5 or SEQ ID NO:7.

27. A process for preparing a soluble CD39 polypeptide comprising culturing a recombinant cell according to claim 21 under conditions that permit expression of the CD39 polypeptide and recovering the CD39 polypeptide from the culture.

28. The process of claim 27 wherein the recombinant cell is a eukaryotic cell.

29. The process of claim 27 wherein the recombinant cell is a CHO cell that has been adapted to grow in suspension and in the absence of serum.
30. A polypeptide produced according to the process of claim 27.
31. A polypeptide produced according to the process of claim 29.
32. A composition comprising a pharmaceutically acceptable carrier and a polypeptide according to one of claims 1-8.
33. A composition comprising a pharmaceutically acceptable carrier and a polypeptide according to claim 30.
34. A composition comprising a pharmaceutically acceptable carrier and a polypeptide according to claim 31.
35. A method of inhibiting angiogenesis in a mammal in need of such treatment comprising administering a therapeutic amount of a soluble CD39 polypeptide.

1/24

Met Glu Asp Thr Lys Glu Ser Asn Val Lys Thr Phe Cys Ser Lys Asn Ile Leu Ala 19  
Ile Leu Gly Phe Ser Ser Ile Ile Ala Val Ile Ala Leu Leu Ala Val Gly Leu Thr 38  
 Gln Asn Lys Ala Leu Pro Glu Asn Val Lys Tyr Gly Ile Val Leu Asp Ala Gly Ser 57  
 Ser His Thr Ser Leu Tyr Ile Tyr Lys Trp Pro Ala Glu Lys Glu Asn Asp Thr Gly 76  
 Val Val His Gln Val Glu Glu Cys Arg Val Lys Gly Pro Gly Ile Ser Lys Phe Val 95  
 Gln Lys Val Asn Glu Ile Gly Ile Tyr Leu Thr Asp Cys Met Glu Arg Ala Arg Glu 114  
 Val Ile Pro Arg Ser Gln His Gln Glu Thr Pro Val Tyr Leu Gly Ala Thr Ala Gly 133  
 Met Arg Leu Leu Arg Met Glu Ser Glu Glu Leu Ala Asp Arg Val Leu Asp Val Val 152  
 Glu Arg Ser Leu Ser Asn Tyr Pro Phe Asp Phe Gln Gly Ala Arg Ile Ile Thr Gly 171  
 Gln Glu Glu Gly Ala Tyr Gly Trp Ile Thr Ile Asn Tyr Leu Leu Gly Lys Phe Ser 190  
 Gln Lys Thr Arg Trp Phe Ser Ile Val Pro Tyr Glu Thr Asn Asn Gln Glu Thr Phe 209  
 Gly Ala Leu Asp Leu Gly Gly Ala Ser Thr Gln Val Thr Phe Val Pro Gln Asn Gln 228  
Thr Ile Glu Ser Pro Asp Asn Ala Leu Gln Phe Arg Leu Tyr Gly Lys Asp Tyr Asn 247  
 Val Tyr Thr His Ser Phe Leu Cys Tyr Gly Lys Asp Gln Ala Leu Trp Gln Lys Leu 266  
 Ala Lys Asp Ile Gln Val Ala Ser Asn Glu Ile Leu Arg Asp Pro Cys Phe His Pro 285  
 Gly Tyr Lys Lys Val Val Asn Val Ser Asp Leu Tyr Lys Thr Pro Cys Thr Lys Arg 304  
 Phe Glu Met Thr Leu Pro Phe Gln Gln Phe Glu Ile Gln Gly Ile Gly Asn Tyr Gln 323  
 Gln Cys His Gln Ser Ile Leu Glu Leu Phe Asn Thr Ser Tyr Cys Pro Tyr Ser Gln 342  
 Cys Ala Phe Asn Gly Ile Phe Leu Pro Pro Leu Gln Gly Asp Phe Gly Ala Phe Ser 361  
 Ala Phe Tyr Phe Val Met Lys Phe Leu Asn Leu Thr Ser Glu Lys Val Ser Gln Glu 380  
 Lys Val Thr Glu Met Met Lys Lys Phe Cys Ala Gln Pro Trp Glu Glu Ile Lys Thr 399  
 Ser Tyr Ala Gly Val Lys Glu Lys Tyr Leu Ser Glu Tyr Cys Phe Ser Gly Thr Tyr 418  
 Ile Leu Ser Leu Leu Leu Gln Gly Tyr His Phe Thr Ala Asp Ser Trp Glu His Ile 437  
 His Phe Ile Gly Lys Ile Gln Gly Ser Asp Ala Gly Trp Thr Leu Gly Tyr Met Leu 456  
Asn Leu Thr Asn Met Ile Pro Ala Glu Gln Pro Leu Ser Thr Pro Leu Ser His Ser 475  
Thr Tyr Val Phe Leu Met Val Leu Phe Ser Leu Val Leu Phe Thr Val Ala Ile Ile 494  
Gly Leu Leu Ile Phe His Lys Pro Ser Tyr Phe Trp Lys Asp Met Val 510

*Fig. 1*

2/24

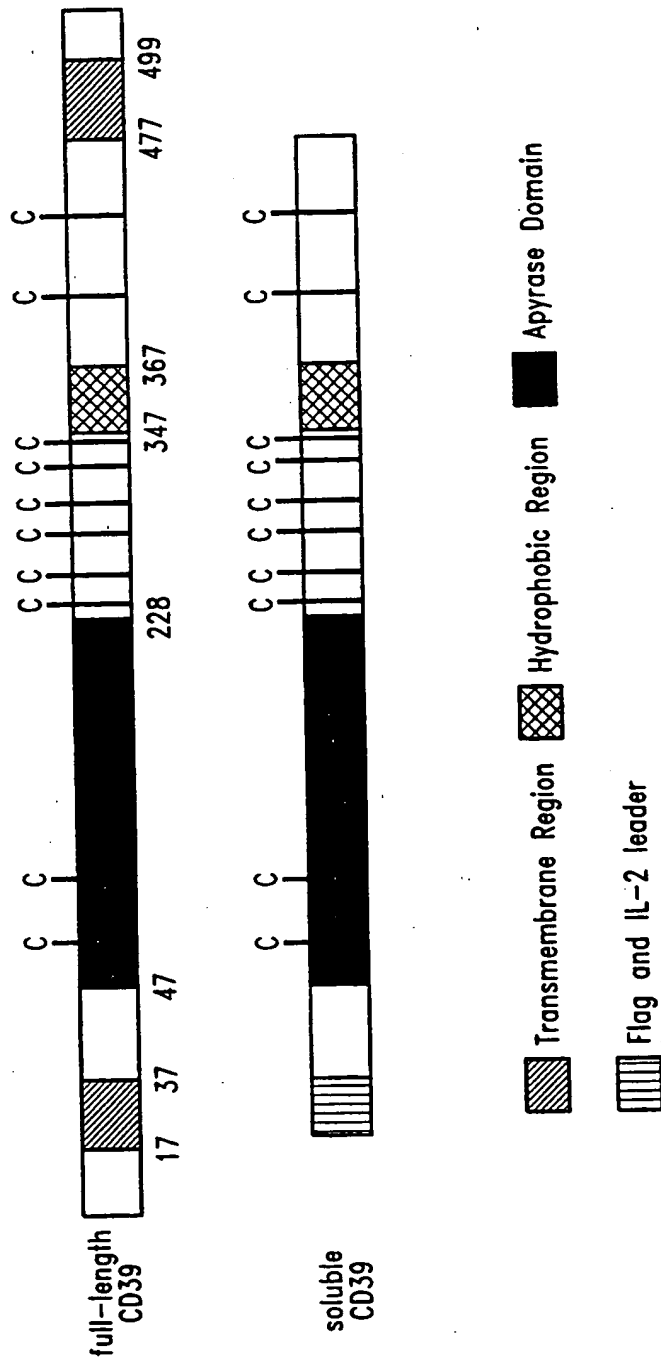


Fig. 2

3/24

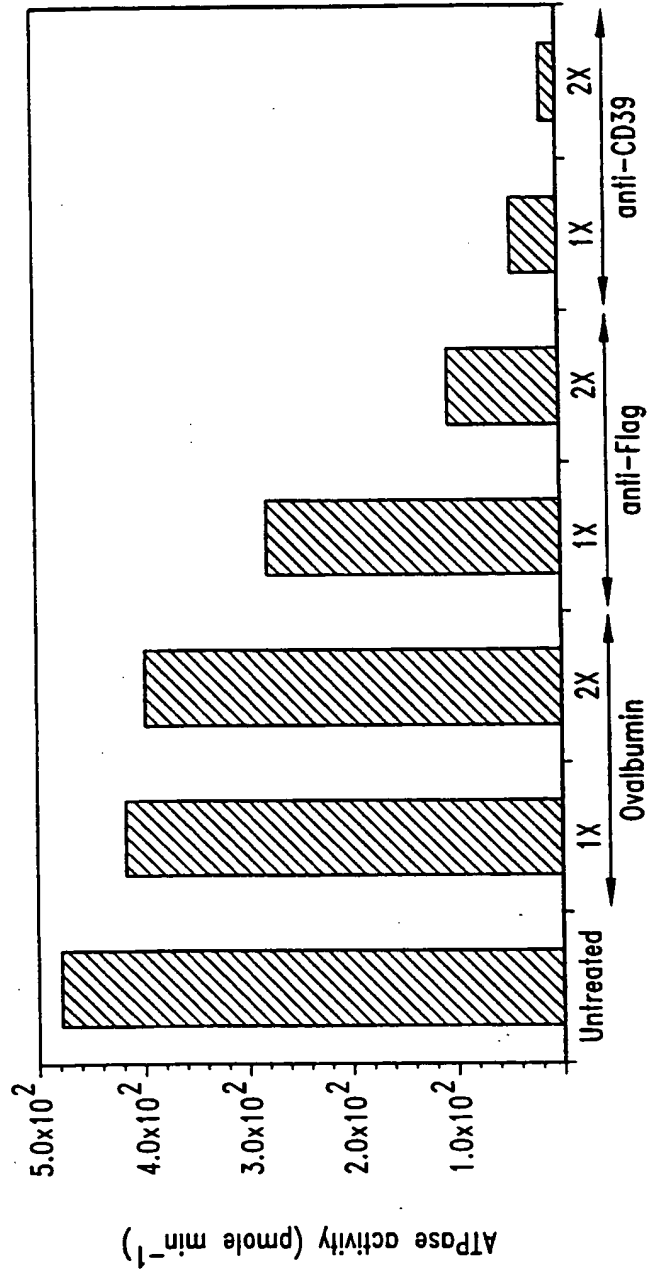


Fig. 3

4/24

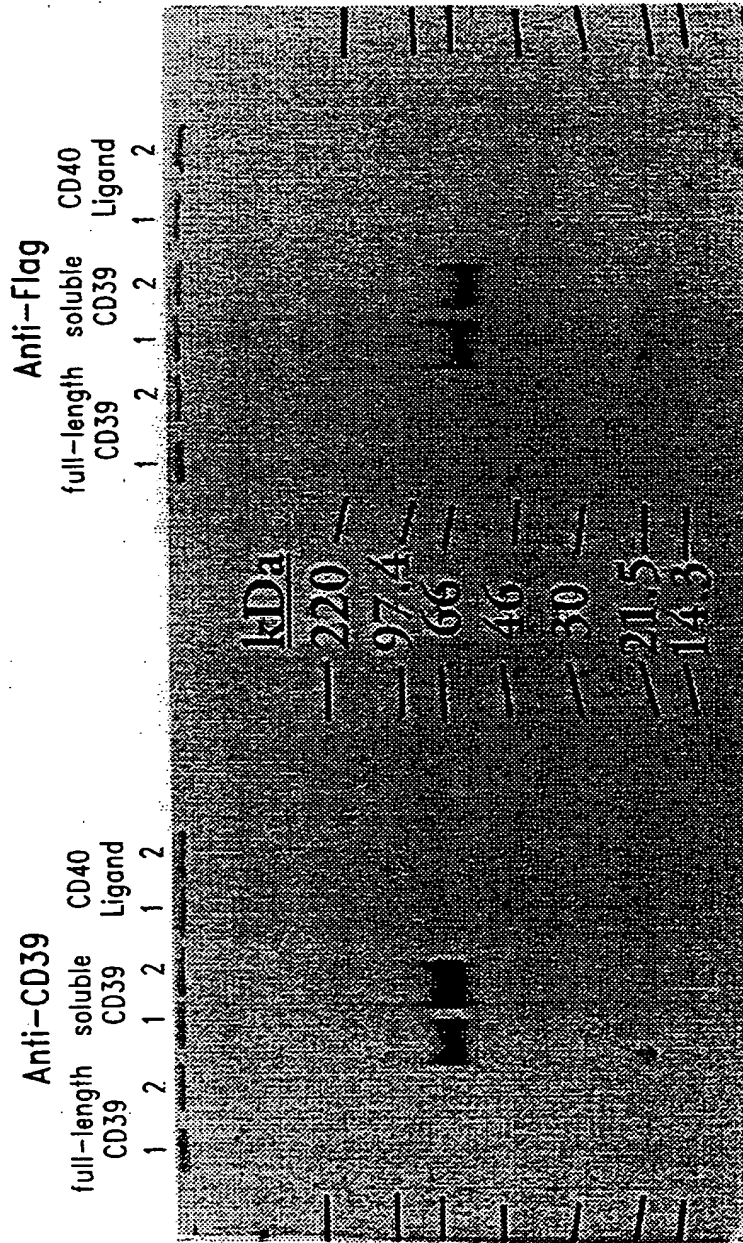
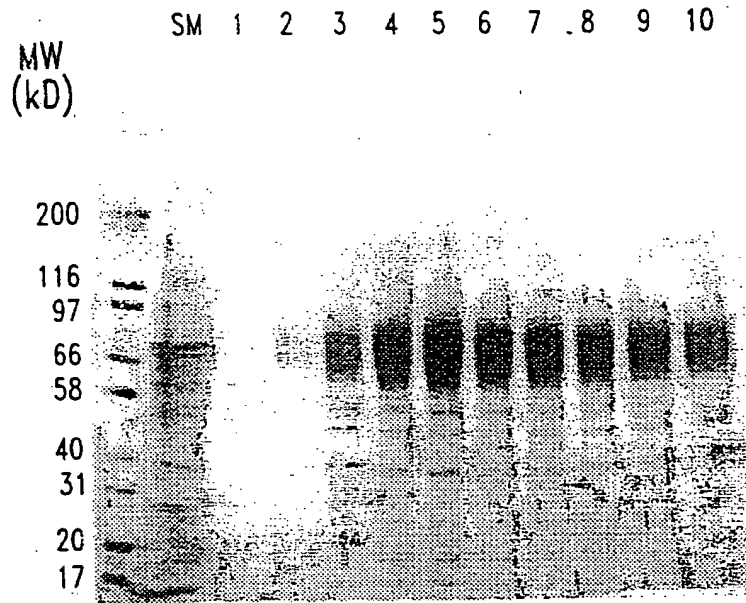


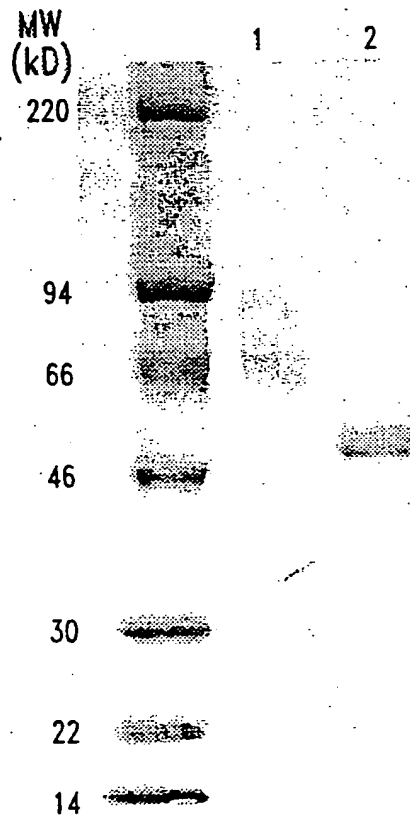
Fig. 4



5/24

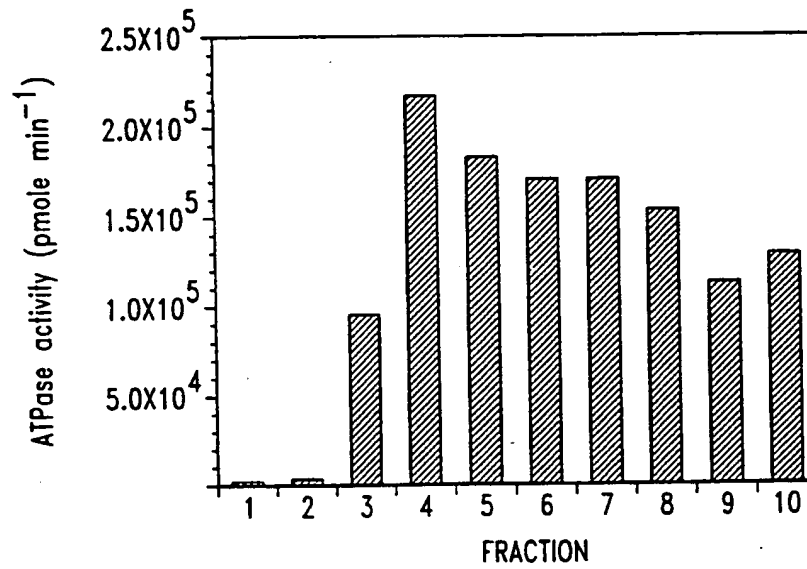


*Fig. 5A*



*Fig. 5C*

6/24

*Fig. 5B*

7/24

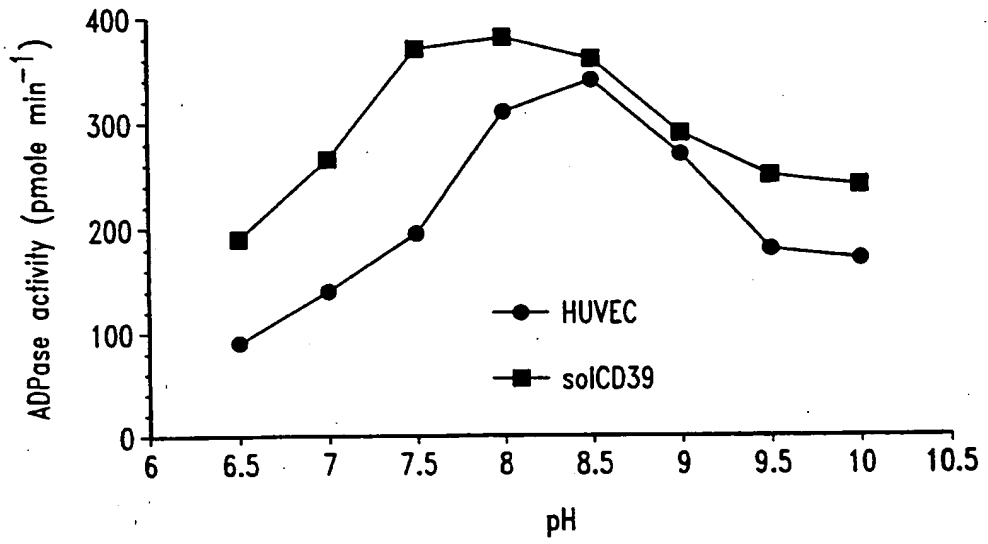


Fig. 6A

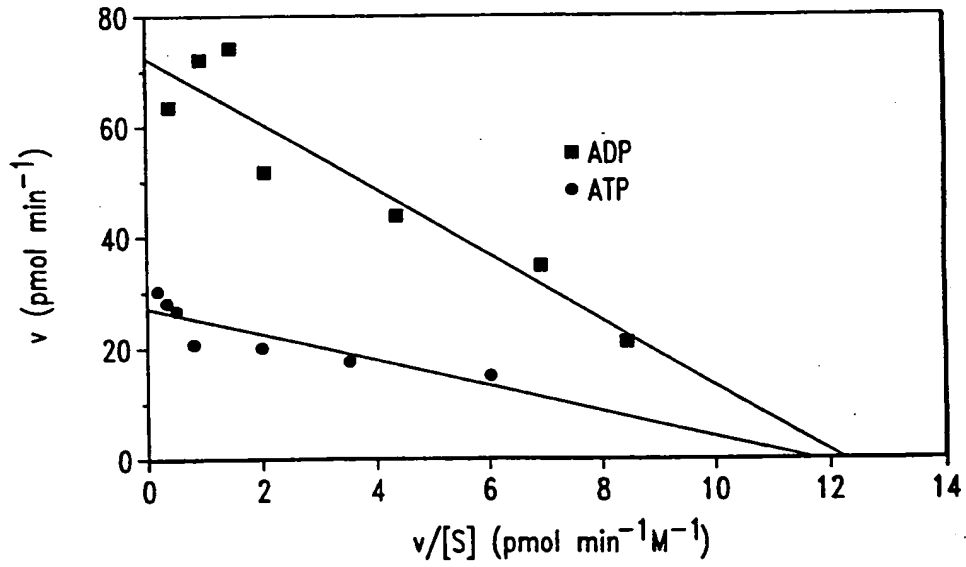


Fig. 6B

8/24

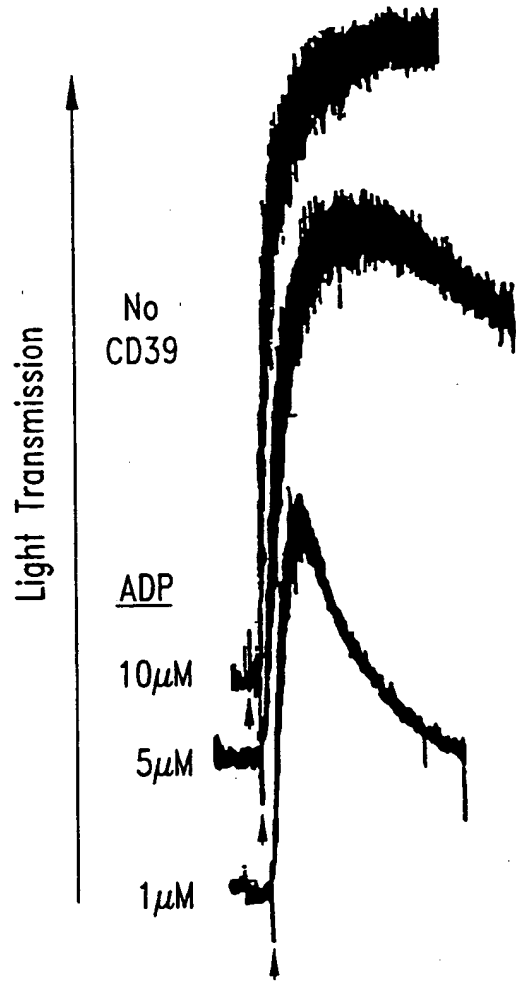


Fig. 7A

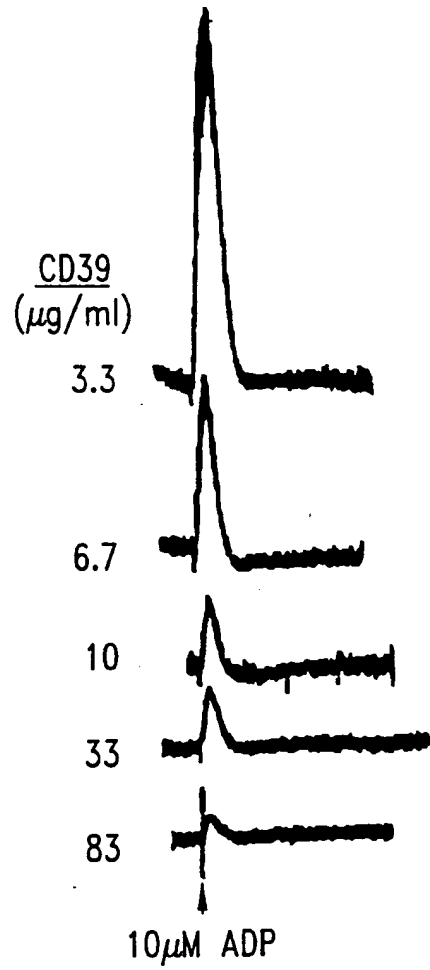


Fig. 7B

9/24

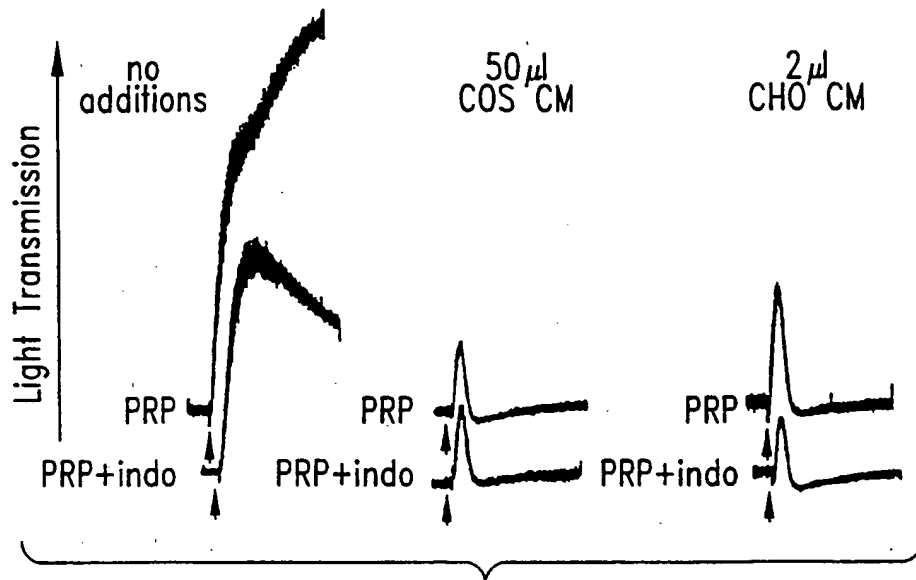


Fig. 8A

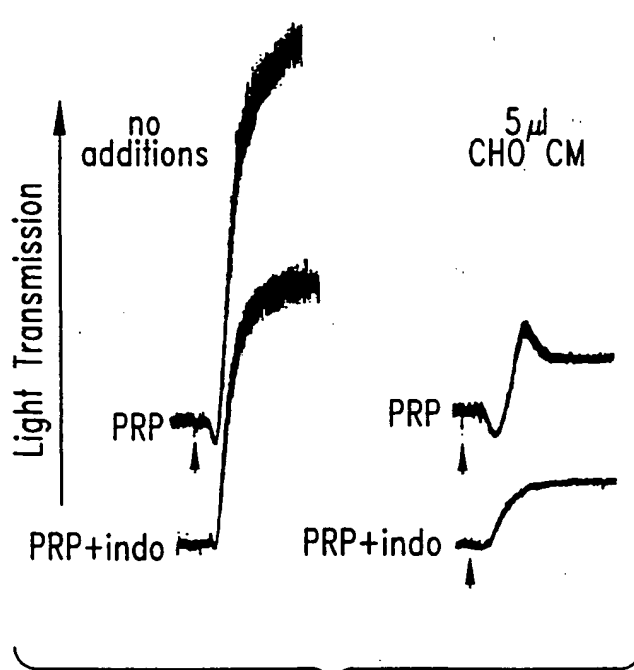


Fig. 8B

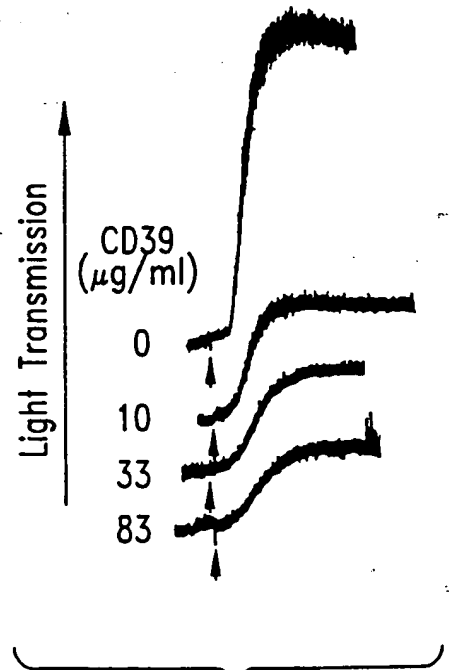
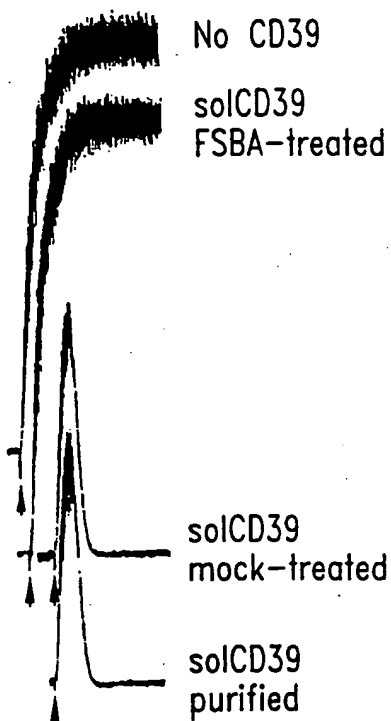
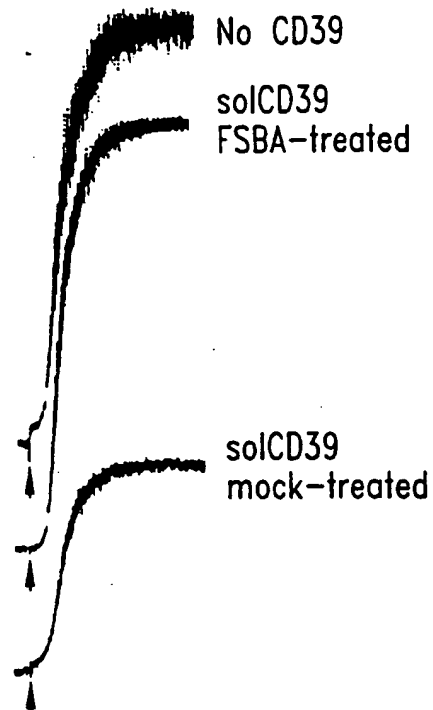


Fig. 8C

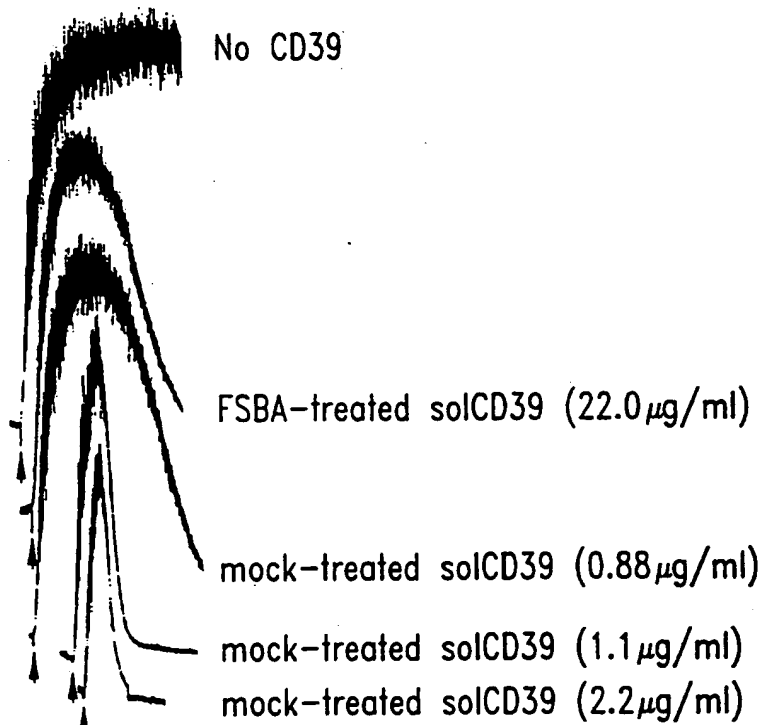
10/24



*Fig. 9A*



*Fig. 9B*



*Fig. 9C*

11/24

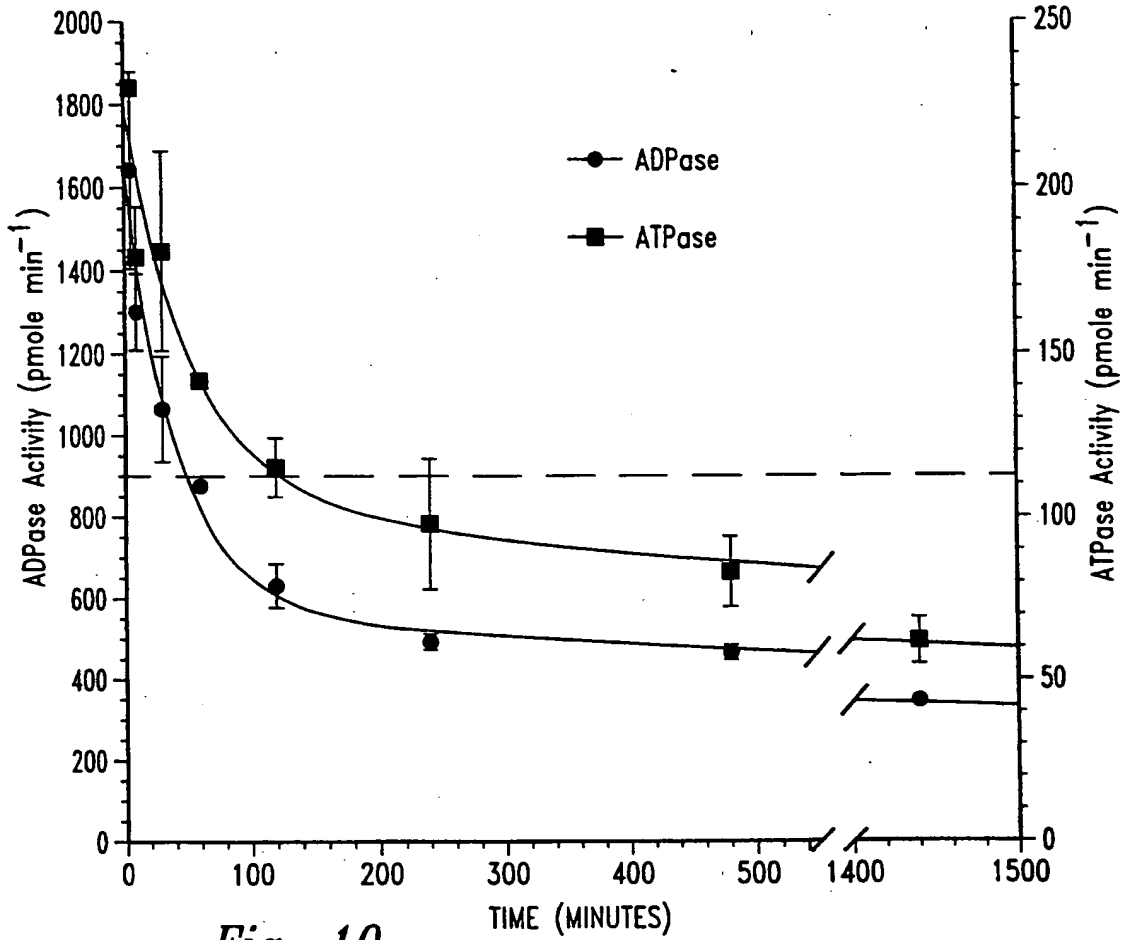


Fig. 10

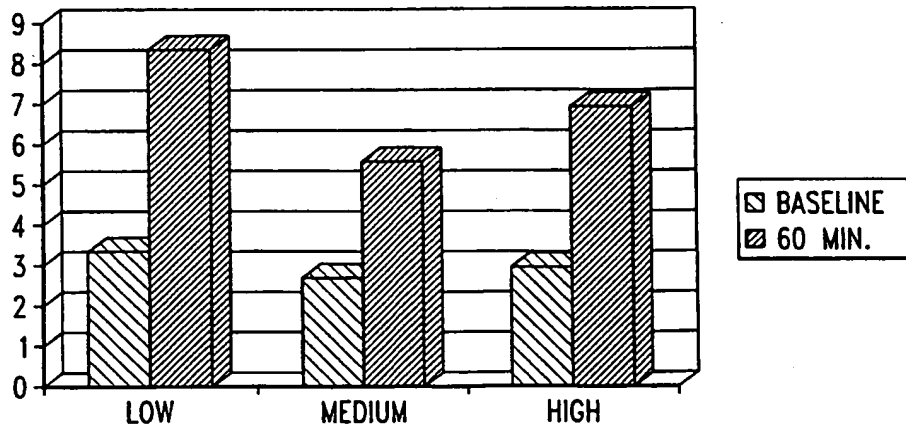
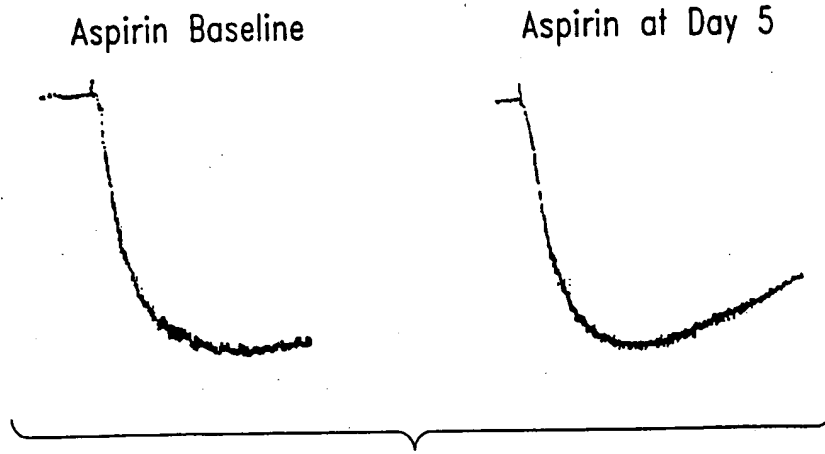
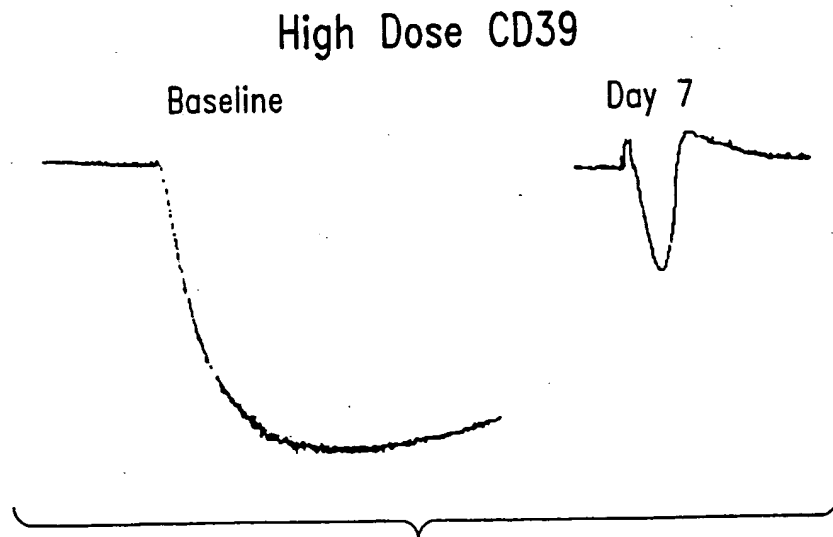


Fig. 11

12/24



*Fig. 12A*



*Fig. 12B*



13/24

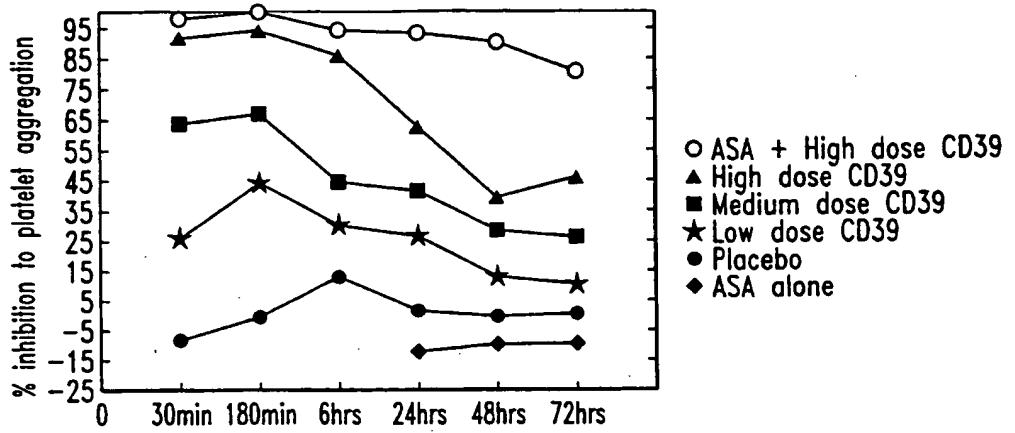


Fig. 13

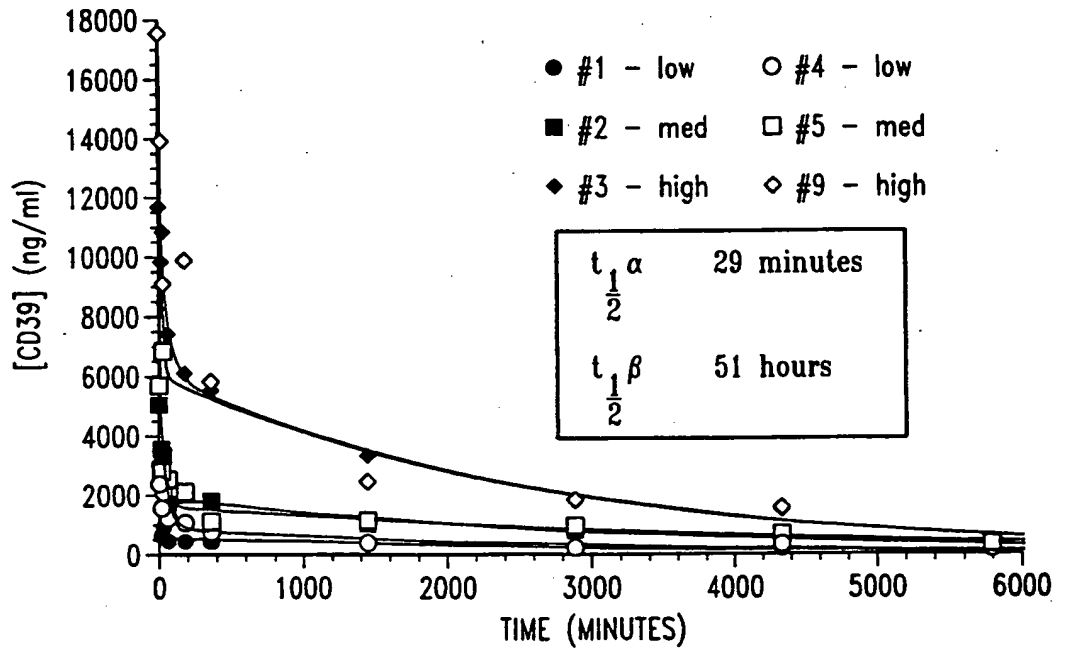
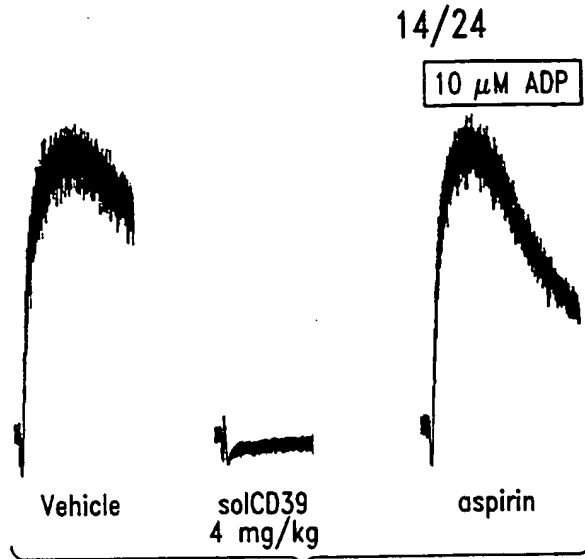
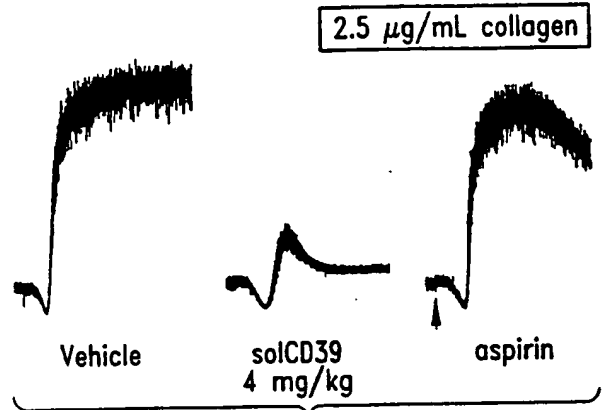


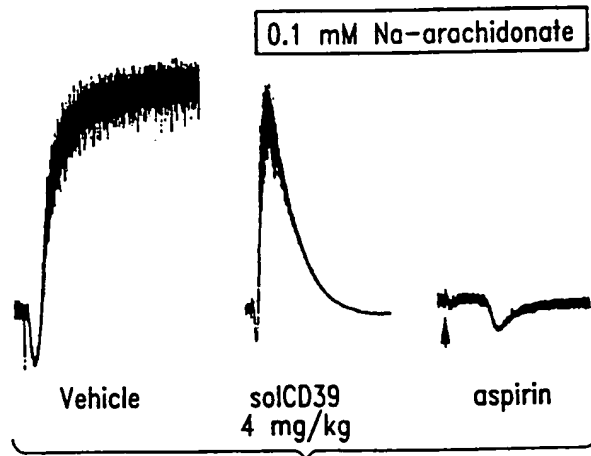
Fig. 14



*Fig. 15A*



*Fig. 15B*



*Fig. 15C*

15/24

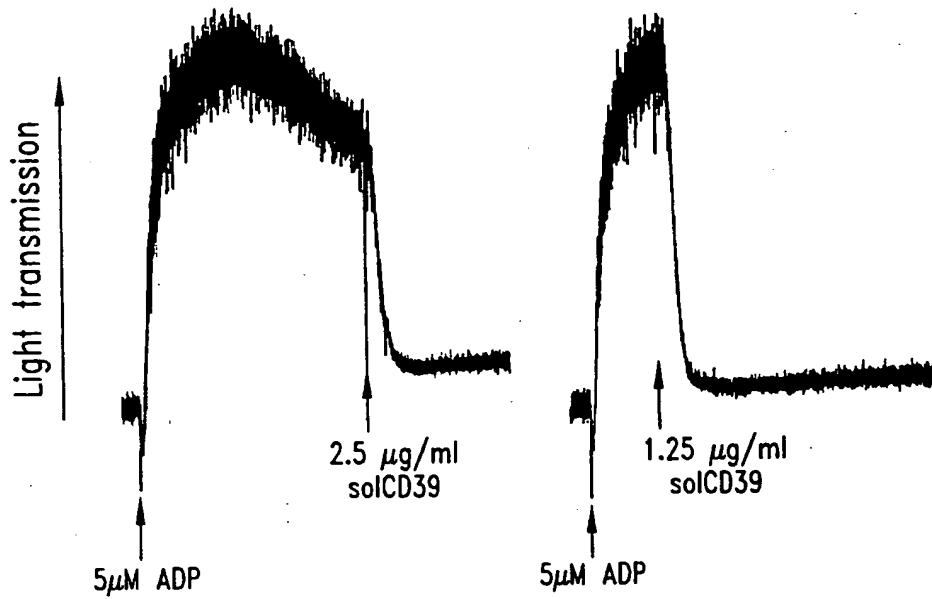


Fig. 16

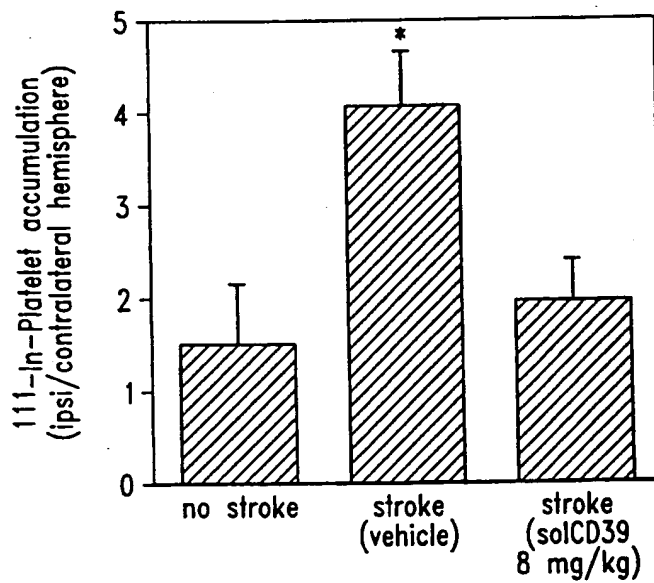
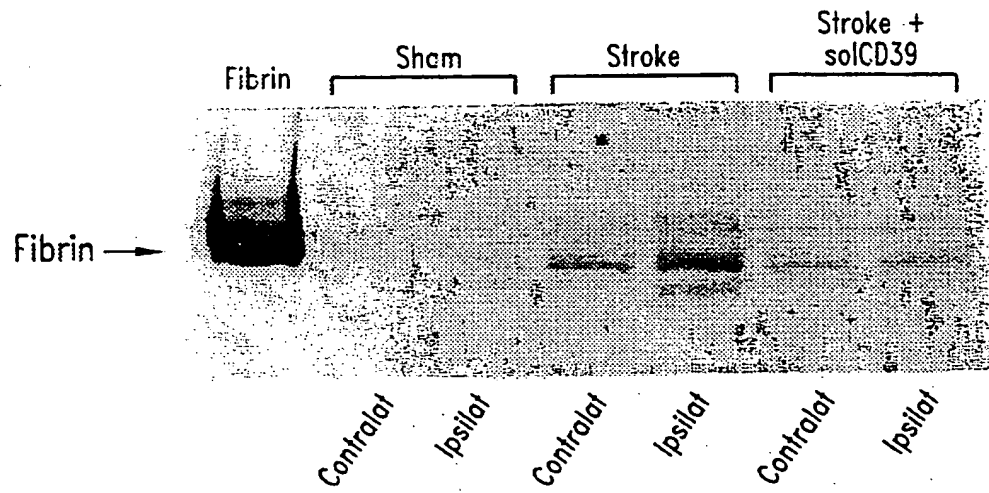
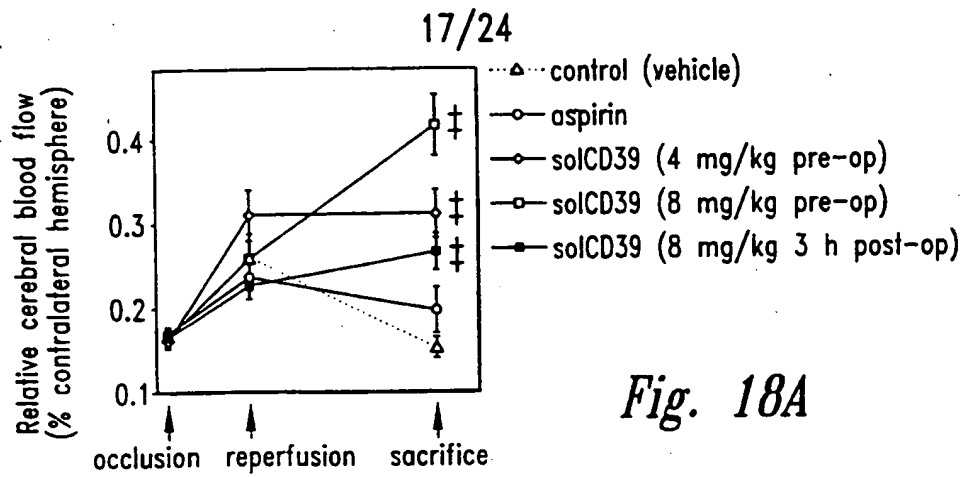


Fig. 17A

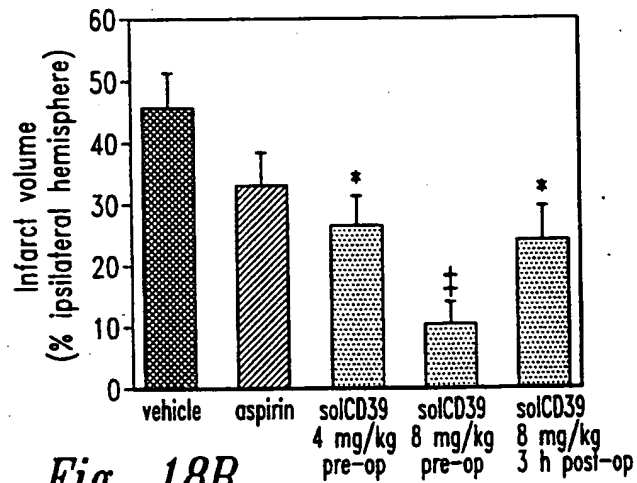
16/24



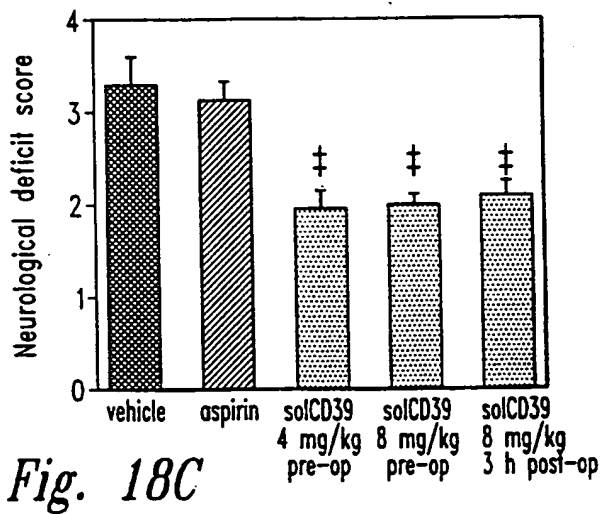
*Fig. 17B*



*Fig. 18A*

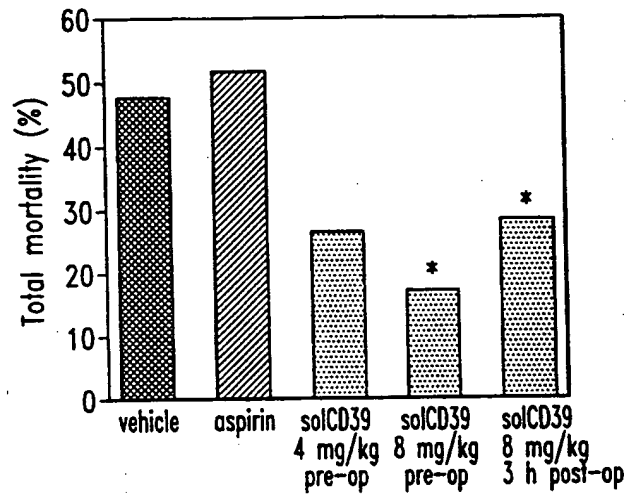


*Fig. 18B*

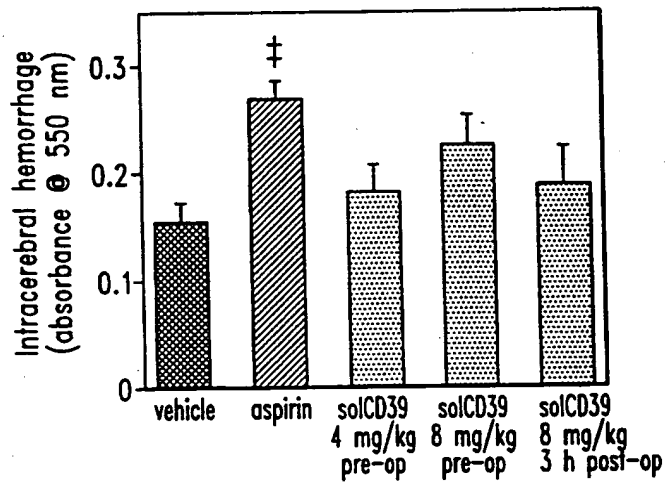


*Fig. 18C*

18/24



*Fig. 18D*



*Fig. 18E*

19/24

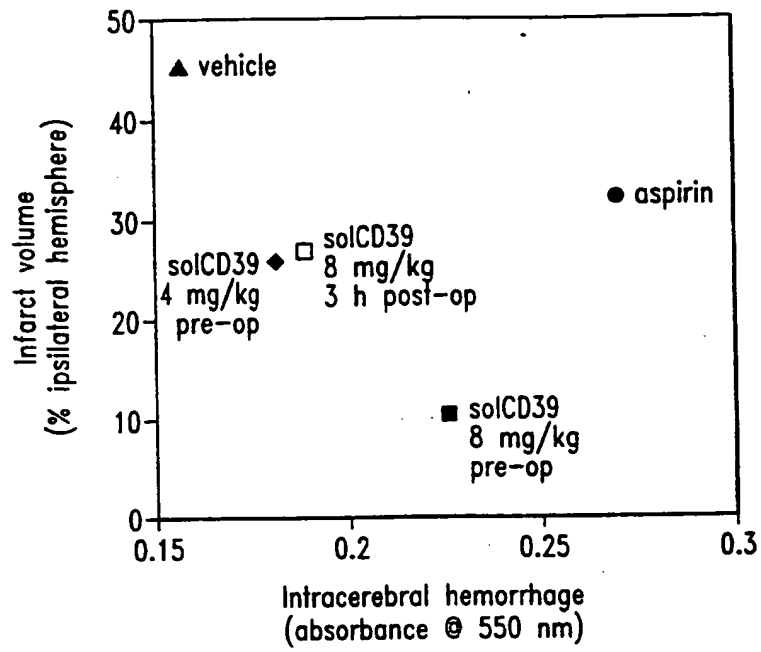


Fig. 19

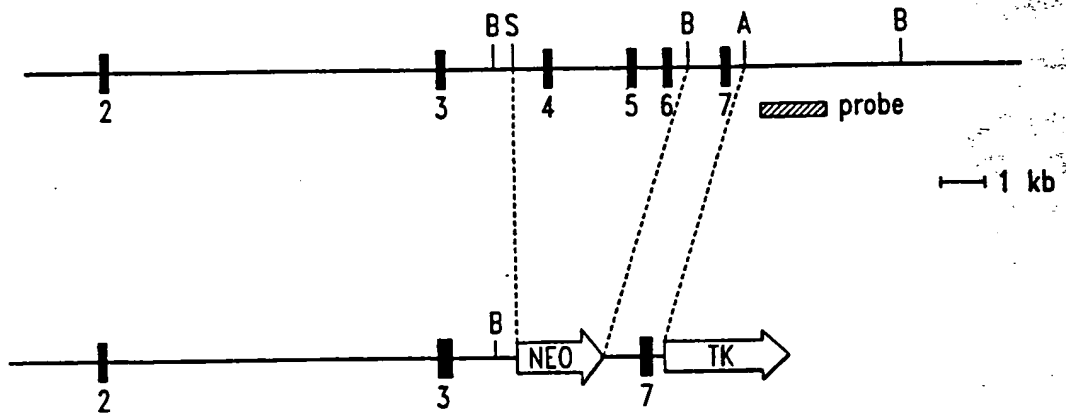
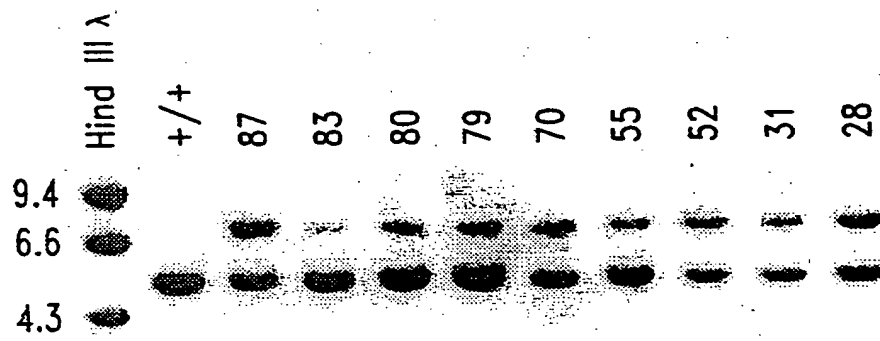


Fig. 20A

20/24



*Fig. 20B*



21/24

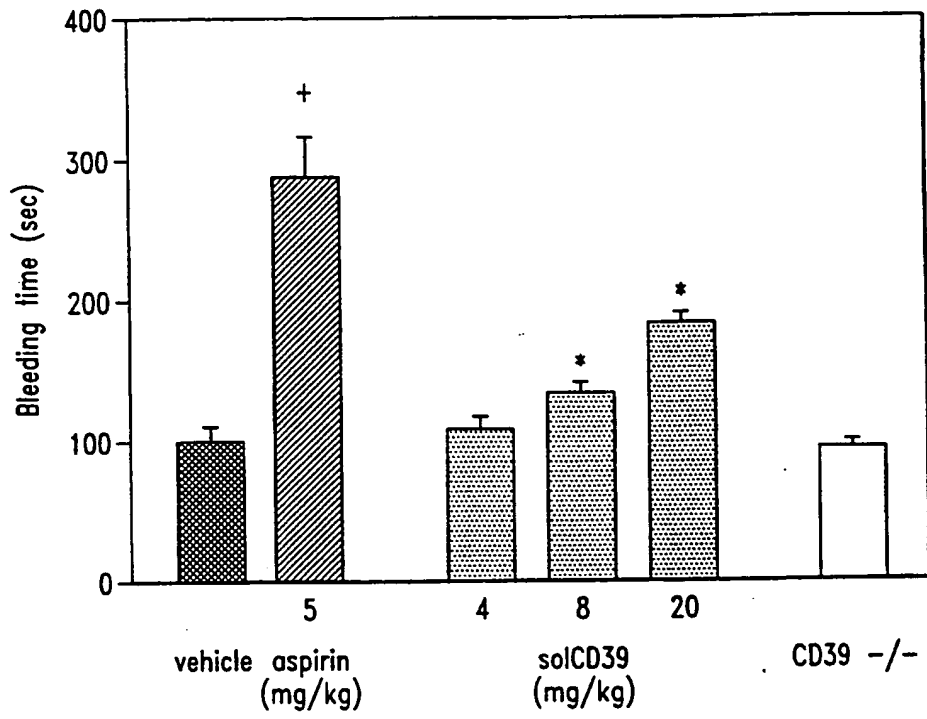


Fig. 21

22/24

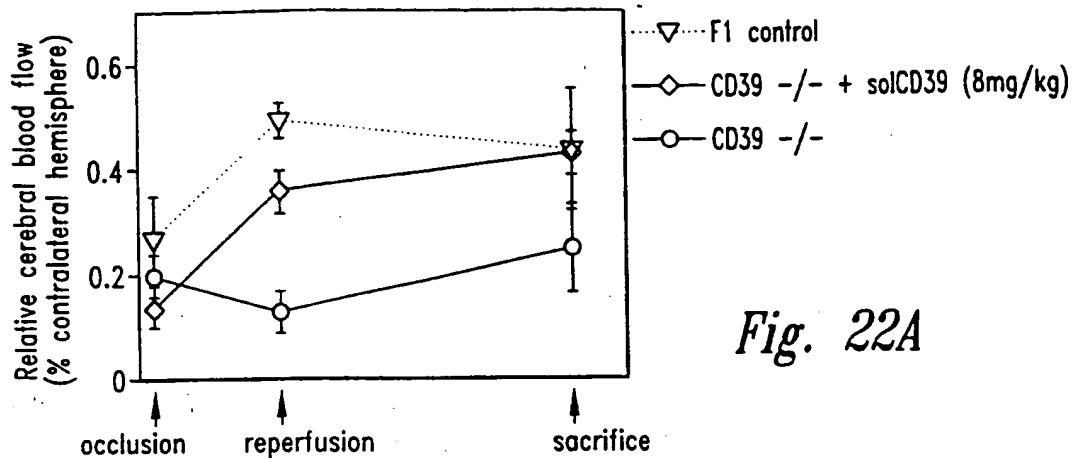


Fig. 22A

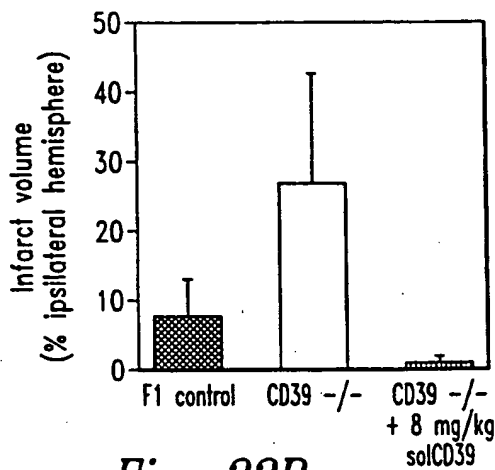


Fig. 22B

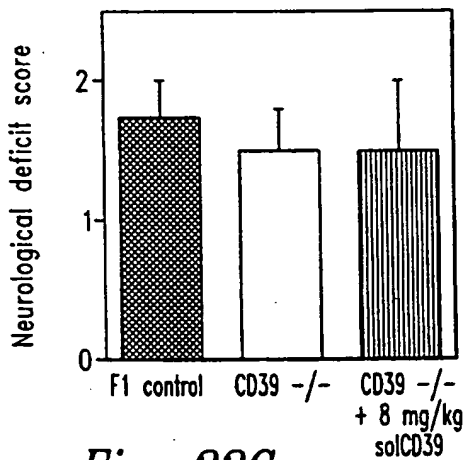
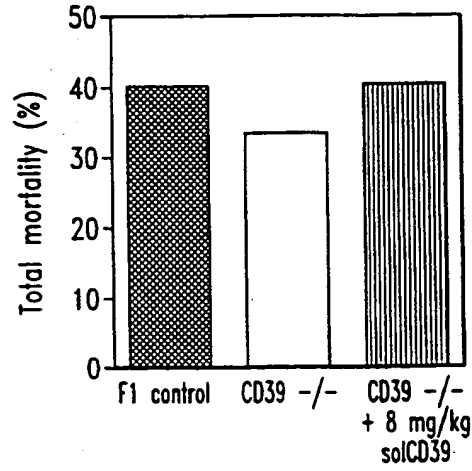
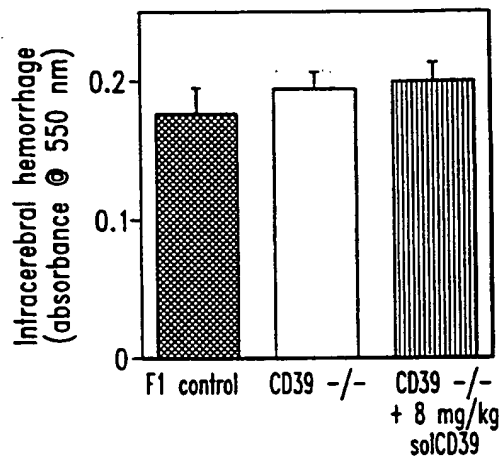


Fig. 22C

23/24

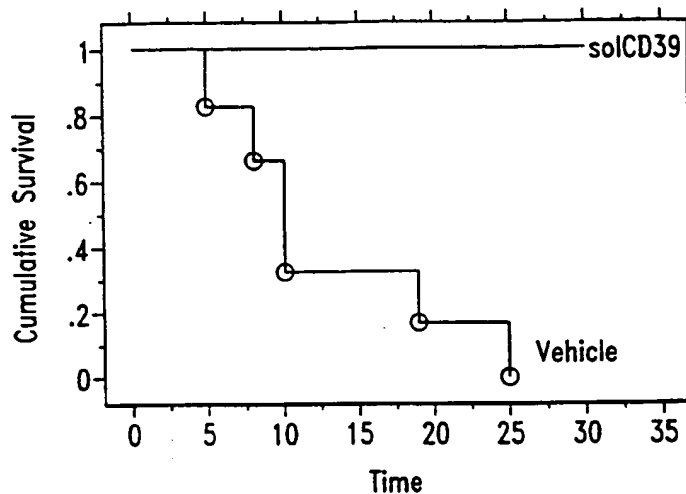


*Fig. 22D*



*Fig. 22E*

24/24



*Fig. 23*

Human CD39 (amino acids 1-69 of SEQ ID NO:2)  
 MEDTKESNVK TFC SKNILAI LGFSSIIAVI ALLAVGLTQN KALPENVKYK IVLDAGSS...  
 | | | | |  
 MATSWGTVFF MLVSCVCSA VSHRNQQTWF EGIFLSSMCP INVSASTLYG IMFDAGST...  
 Human CD39-L4 (SEQ ID NO:31)

*Fig. 24*

SEQUENCE LISTING

<110> Maliszewski, Charles R.  
 Gayle III, Richard B.  
 Price, Virginia L.  
 Gimpel, Steven D.  
 Immunex Corporation

<120> Inhibitors of Platelet Activation and Recruitment

<130> 2879-WO

<140>  
 <141>

<150> US 60/104,585  
 <151> 1998-10-16

<150> US 60/107,466  
 <151> 1998-11-06

<150> US 60/149,010  
 <151> 1999-08-13

<160> 31

<170> PatentIn Ver. 2.0

<210> 1  
 <211> 1599  
 <212> DNA  
 <213> Homo sapiens

<220>  
 <221> CDS  
 <222> (67)..(1596)

<400> 1  
 ccacaccaag cagcggctgg ggggggaaa gacgaggaaa gaggaggaaa acaaaagctg 60  
 ctactt atg gaa gat aca aag gag tct aac gtg aag aca ttt tgc tcc 108  
 Met Glu Asp Thr Lys Glu Ser Asn Val Lys Thr Phe Cys Ser  
 1 5 10  
 aag aat atc cta gcc atc ctt ggc ttc tcc tct atc ata gct gtg ata 156  
 Lys Asn Ile Leu Ala Ile Leu Gly Phe Ser Ser Ile Ile Ala Val Ile  
 15 20 25 30  
 gct ttg ctt gct gtg ggg ttg acc cag aac aaa gca ttg cca gaa aac 204  
 Ala Leu Leu Ala Val Gly Leu Thr Gln Asn Lys Ala Leu Pro Glu Asn  
 35 40 45  
 gtt aag tat ggg att gtg ctg gat gcg ggt tct tct cac aca agt tta 252  
 Val Lys Tyr Gly Ile Val Leu Asp Ala Gly Ser Ser His Thr Ser Leu  
 50 55 60  
 tac atc tat aag tgg cca gca gaa aag gag aat gac aca ggc gtg gtg 300

Tyr	Ile	Tyr	Lys	Trp	Pro	Ala	Glu	Lys	Glu	Asn	Asp	Thr	Gly	Val	Val	
		65					70					75				
cat	caa	gta	gaa	gaa	tgc	agg	ggt	aaa	ggt	cct	gga	atc	tca	aaa	ttt	348
His	Gln	Val	Glu	Glu	Cys	Arg	Val	Lys	Gly	Pro	Gly	Ile	Ser	Lys	Phe	
	80					85					90					
gtt	cag	aaa	gta	aat	gaa	ata	ggc	att	tac	ctg	act	gat	tgc	atg	gaa	396
Val	Gln	Lys	Val	Asn	Glu	Ile	Gly	Ile	Tyr	Leu	Thr	Asp	Cys	Met	Glu	
	95				100					105					110	
aga	gct	agg	gaa	gtg	att	cca	agg	tcc	cag	cac	caa	gag	aca	ccc	gtt	444
Arg	Ala	Arg	Glu	Val	Ile	Pro	Arg	Ser	Gln	His	Gln	Glu	Thr	Pro	Val	
				115					120					125		
tac	ctg	gga	gcc	acg	gca	ggc	atg	cgg	ttg	ctc	agg	atg	gaa	agt	gaa	492
Tyr	Leu	Gly	Ala	Thr	Ala	Gly	Met	Arg	Leu	Leu	Arg	Met	Glu	Ser	Glu	
			130					135					140			
gag	ttg	gca	gac	agg	ggt	ctg	gat	gtg	gtg	gag	agg	agc	ctc	agc	aac	540
Glu	Leu	Ala	Asp	Arg	Val	Leu	Asp	Val	Val	Glu	Arg	Ser	Leu	Ser	Asn	
		145					150					155				
tac	ccc	ttt	gac	ttc	cag	ggt	gcc	agg	atc	att	act	ggc	caa	gag	gaa	588
Tyr	Pro	Phe	Asp	Phe	Gln	Gly	Ala	Arg	Ile	Ile	Thr	Gly	Gln	Glu	Glu	
	160					165					170					
ggt	gcc	tat	ggc	tgg	att	act	atc	aac	tat	ctg	ctg	ggc	aaa	ttc	agt	636
Gly	Ala	Tyr	Gly	Trp	Ile	Thr	Ile	Asn	Tyr	Leu	Leu	Gly	Lys	Phe	Ser	
	175				180					185					190	
cag	aaa	aca	agg	tgg	ttc	agc	ata	gtc	cca	tat	gaa	acc	aat	aat	cag	684
Gln	Lys	Thr	Arg	Trp	Phe	Ser	Ile	Val	Pro	Tyr	Glu	Thr	Asn	Asn	Gln	
				195					200					205		
gaa	acc	ttt	gga	gct	ttg	gac	ctt	ggg	gga	gcc	tct	aca	caa	gtc	act	732
Glu	Thr	Phe	Gly	Ala	Leu	Asp	Leu	Gly	Gly	Ala	Ser	Thr	Gln	Val	Thr	
			210					215					220			
ttt	gta	ccc	caa	aac	cag	act	atc	gag	tcc	cca	gat	aat	gct	ctg	caa	780
Phe	Val	Pro	Gln	Asn	Gln	Thr	Ile	Glu	Ser	Pro	Asp	Asn	Ala	Leu	Gln	
		225					230					235				
ttt	cgc	ctc	tat	ggc	aag	gac	tac	aat	gtc	tac	aca	cat	agc	ttc	ttg	828
Phe	Arg	Leu	Tyr	Gly	Lys	Asp	Tyr	Asn	Val	Tyr	Thr	His	Ser	Phe	Leu	
	240					245					250					
tgc	tat	ggg	aag	gat	cag	gca	ctc	tgg	cag	aaa	ctg	gcc	aag	gac	att	876
Cys	Tyr	Gly	Lys	Asp	Gln	Ala	Leu	Trp	Gln	Lys	Leu	Ala	Lys	Asp	Ile	
	255				260					265					270	
cag	ggt	gca	agt	aat	gaa	att	ctc	agg	gac	cca	tgc	ttt	cat	cct	gga	924
Gln	Val	Ala	Ser	Asn	Glu	Ile	Leu	Arg	Asp	Pro	Cys	Phe	His	Pro	Gly	
				275					280					285		
tat	aag	aag	gta	gtg	aac	gta	agt	gac	ctt	tac	aag	acc	ccc	tgc	acc	972
Tyr	Lys	Lys	Val	Val	Asn	Val	Ser	Asp	Leu	Tyr	Lys	Thr	Pro	Cys	Thr	
			290					295					300			

aag aga ttt gag atg act ctt cca ttc cag cag ttt gaa atc cag ggt 1020  
 Lys Arg Phe Glu Met Thr Leu Pro Phe Gln Gln Phe Glu Ile Gln Gly  
 305 310 315

att gga aac tat caa caa tgc cat caa agc atc ctg gag ctc ttc aac 1068  
 Ile Gly Asn Tyr Gln Gln Cys His Gln Ser Ile Leu Glu Leu Phe Asn  
 320 325 330

acc agt tac tgc cct tac tcc cag tgt gcc ttc aat ggg att ttc ttg 1116  
 Thr Ser Tyr Cys Pro Tyr Ser Gln Cys Ala Phe Asn Gly Ile Phe Leu  
 335 340 345 350

cca cca ctc cag ggg gat ttt ggg gca ttt tca gct ttt tac ttt gtg 1164  
 Pro Pro Leu Gln Gly Asp Phe Gly Ala Phe Ser Ala Phe Tyr Phe Val  
 355 360 365

atg aag ttt tta aac ttg aca tca gag aaa gtc tct cag gaa aag gtg 1212  
 Met Lys Phe Leu Asn Leu Thr Ser Glu Lys Val Ser Gln Glu Lys Val  
 370 375 380

act gag atg atg aaa aag ttc tgt gct cag cct tgg gag gag ata aaa 1260  
 Thr Glu Met Met Lys Lys Phe Cys Ala Gln Pro Trp Glu Glu Ile Lys  
 385 390 395

aca tct tac gct gga gta aag gag aag tac ctg agt gaa tac tgc ttt 1308  
 Thr Ser Tyr Ala Gly Val Lys Glu Lys Tyr Leu Ser Glu Tyr Cys Phe  
 400 405 410

tct ggt acc tac att ctc tcc ctc ctt ctg caa ggc tat cat ttc aca 1356  
 Ser Gly Thr Tyr Ile Leu Ser Leu Leu Leu Gln Gly Tyr His Phe Thr  
 415 420 425 430

gct gat tcc tgg gag cac atc cat ttc att ggc aag atc cag ggc agc 1404  
 Ala Asp Ser Trp Glu His Ile His Phe Ile Gly Lys Ile Gln Gly Ser  
 435 440 445

gac gcc ggc tgg act ttg ggc tac atg ctg aac ctg acc aac atg atc 1452  
 Asp Ala Gly Trp Thr Leu Gly Tyr Met Leu Asn Leu Thr Asn Met Ile  
 450 455 460

cca gct gag caa cca ttg tcc aca cct ctc tcc cac tcc acc tat gtc 1500  
 Pro Ala Glu Gln Pro Leu Ser Thr Pro Leu Ser His Ser Thr Tyr Val  
 465 470 475

ttc ctc atg gtt cta ttc tcc ctg gtc ctt ttc aca gtg gcc atc ata 1548  
 Phe Leu Met Val Leu Phe Ser Leu Val Leu Phe Thr Val Ala Ile Ile  
 480 485 490

ggc ttg ctt atc ttt cac aag cct tca tat ttc tgg aaa gat atg gta 1596  
 Gly Leu Leu Ile Phe His Lys Pro Ser Tyr Phe Trp Lys Asp Met Val  
 495 500 505 510

tag 1599

<210> 2  
 <211> 510

&lt;212&gt; PRT

&lt;213&gt; Homo sapiens

&lt;400&gt; 2

Met Glu Asp Thr Lys Glu Ser Asn Val Lys Thr Phe Cys Ser Lys Asn  
 1 5 10 15

Ile Leu Ala Ile Leu Gly Phe Ser Ser Ile Ile Ala Val Ile Ala Leu  
 20 25 30

Leu Ala Val Gly Leu Thr Gln Asn Lys Ala Leu Pro Glu Asn Val Lys  
 35 40 45

Tyr Gly Ile Val Leu Asp Ala Gly Ser Ser His Thr Ser Leu Tyr Ile  
 50 55 60

Tyr Lys Trp Pro Ala Glu Lys Glu Asn Asp Thr Gly Val Val His Gln  
 65 70 75 80

Val Glu Glu Cys Arg Val Lys Gly Pro Gly Ile Ser Lys Phe Val Gln  
 85 90 95

Lys Val Asn Glu Ile Gly Ile Tyr Leu Thr Asp Cys Met Glu Arg Ala  
 100 105 110

Arg Glu Val Ile Pro Arg Ser Gln His Gln Glu Thr Pro Val Tyr Leu  
 115 120 125

Gly Ala Thr Ala Gly Met Arg Leu Leu Arg Met Glu Ser Glu Glu Leu  
 130 135 140

Ala Asp Arg Val Leu Asp Val Val Glu Arg Ser Leu Ser Asn Tyr Pro  
 145 150 155 160

Phe Asp Phe Gln Gly Ala Arg Ile Ile Thr Gly Gln Glu Glu Gly Ala  
 165 170 175

Tyr Gly Trp Ile Thr Ile Asn Tyr Leu Leu Gly Lys Phe Ser Gln Lys  
 180 185 190

Thr Arg Trp Phe Ser Ile Val Pro Tyr Glu Thr Asn Asn Gln Glu Thr  
 195 200 205

Phe Gly Ala Leu Asp Leu Gly Gly Ala Ser Thr Gln Val Thr Phe Val  
 210 215 220

Pro Gln Asn Gln Thr Ile Glu Ser Pro Asp Asn Ala Leu Gln Phe Arg  
 225 230 235 240

Leu Tyr Gly Lys Asp Tyr Asn Val Tyr Thr His Ser Phe Leu Cys Tyr  
 245 250 255

Gly Lys Asp Gln Ala Leu Trp Gln Lys Leu Ala Lys Asp Ile Gln Val  
 260 265 270

Ala Ser Asn Glu Ile Leu Arg Asp Pro Cys Phe His Pro Gly Tyr Lys  
 275 280 285



Lys Val Val Asn Val Ser Asp Leu Tyr Lys Thr Pro Cys Thr Lys Arg  
 290 295 300

Phe Glu Met Thr Leu Pro Phe Gln Gln Phe Glu Ile Gln Gly Ile Gly  
 305 310 315 320

Asn Tyr Gln Gln Cys His Gln Ser Ile Leu Glu Leu Phe Asn Thr Ser  
 325 330 335

Tyr Cys Pro Tyr Ser Gln Cys Ala Phe Asn Gly Ile Phe Leu Pro Pro  
 340 345 350

Leu Gln Gly Asp Phe Gly Ala Phe Ser Ala Phe Tyr Phe Val Met Lys  
 355 360 365

Phe Leu Asn Leu Thr Ser Glu Lys Val Ser Gln Glu Lys Val Thr Glu  
 370 375 380

Met Met Lys Lys Phe Cys Ala Gln Pro Trp Glu Glu Ile Lys Thr Ser  
 385 390 395 400

Tyr Ala Gly Val Lys Glu Lys Tyr Leu Ser Glu Tyr Cys Phe Ser Gly  
 405 410 415

Thr Tyr Ile Leu Ser Leu Leu Leu Gln Gly Tyr His Phe Thr Ala Asp  
 420 425 430

Ser Trp Glu His Ile His Phe Ile Gly Lys Ile Gln Gly Ser Asp Ala  
 435 440 445

Gly Trp Thr Leu Gly Tyr Met Leu Asn Leu Thr Asn Met Ile Pro Ala  
 450 455 460

Glu Gln Pro Leu Ser Thr Pro Leu Ser His Ser Thr Tyr Val Phe Leu  
 465 470 475 480

Met Val Leu Phe Ser Leu Val Leu Phe Thr Val Ala Ile Ile Gly Leu  
 485 490 495

Leu Ile Phe His Lys Pro Ser Tyr Phe Trp Lys Asp Met Val  
 500 505 510

<210> 3  
 <211> 476  
 <212> PRT  
 <213> Artificial Sequence

<220>  
 <223> Description of Artificial Sequence: Fusion  
 construct of human CD39

<400> 3  
 Met Ala Thr Ser Trp Gly Thr Val Phe Phe Met Leu Val Val Ser Cys  
 1 5 10 15

Val Cys Ser Ala Val Ser His Arg Asn Gln Gln Thr Trp Phe Glu Gly  
 20 25 30

Ile Phe Leu Ser Ser Thr Gln Asn Lys Ala Leu Pro Glu Asn Val Lys  
 35 40 45  
 Tyr Gly Ile Val Leu Asp Ala Gly Ser Ser His Thr Ser Leu Tyr Ile  
 50 55 60  
 Tyr Lys Trp Pro Ala Glu Lys Glu Asn Asp Thr Gly Val Val His Gln  
 65 70 75 80  
 Val Glu Glu Cys Arg Val Lys Gly Pro Gly Ile Ser Lys Phe Val Gln  
 85 90 95  
 Lys Val Asn Glu Ile Gly Ile Tyr Leu Thr Asp Cys Met Glu Arg Ala  
 100 105 110  
 Arg Glu Val Ile Pro Arg Ser Gln His Gln Glu Thr Pro Val Tyr Leu  
 115 120 125  
 Gly Ala Thr Ala Gly Met Arg Leu Leu Arg Met Glu Ser Glu Glu Leu  
 130 135 140  
 Ala Asp Arg Val Leu Asp Val Val Glu Arg Ser Leu Ser Asn Tyr Pro  
 145 150 155 160  
 Phe Asp Phe Gln Gly Ala Arg Ile Ile Thr Gly Gln Glu Glu Gly Ala  
 165 170 175  
 Tyr Gly Trp Ile Thr Ile Asn Tyr Leu Leu Gly Lys Phe Ser Gln Lys  
 180 185 190  
 Thr Arg Trp Phe Ser Ile Val Pro Tyr Glu Thr Asn Asn Gln Glu Thr  
 195 200 205  
 Phe Gly Ala Leu Asp Leu Gly Gly Ala Ser Thr Gln Val Thr Phe Val  
 210 215 220  
 Pro Gln Asn Gln Thr Ile Glu Ser Pro Asp Asn Ala Leu Gln Phe Arg  
 225 230 235 240  
 Leu Tyr Gly Lys Asp Tyr Asn Val Tyr Thr His Ser Phe Leu Cys Tyr  
 245 250 255  
 Gly Lys Asp Gln Ala Leu Trp Gln Lys Leu Ala Lys Asp Ile Gln Val  
 260 265 270  
 Ala Ser Asn Glu Ile Leu Arg Asp Pro Cys Phe His Pro Gly Tyr Lys  
 275 280 285  
 Lys Val Val Asn Val Ser Asp Leu Tyr Lys Thr Pro Cys Thr Lys Arg  
 290 295 300  
 Phe Glu Met Thr Leu Pro Phe Gln Gln Phe Glu Ile Gln Gly Ile Gly  
 305 310 315 320  
 Asn Tyr Gln Gln Cys His Gln Ser Ile Leu Glu Leu Phe Asn Thr Ser  
 325 330 335

Tyr Cys Pro Tyr Ser Gln Cys Ala Phe Asn Gly Ile Phe Leu Pro Pro  
 340 345 350

Leu Gln Gly Asp Phe Gly Ala Phe Ser Ala Phe Tyr Phe Val Met Lys  
 355 360 365

Phe Leu Asn Leu Thr Ser Glu Lys Val Ser Gln Glu Lys Val Thr Glu  
 370 375 380

Met Met Lys Lys Phe Cys Ala Gln Pro Trp Glu Glu Ile Lys Thr Ser  
 385 390 395 400

Tyr Ala Gly Val Lys Glu Lys Tyr Leu Ser Glu Tyr Cys Phe Ser Gly  
 405 410 415

Thr Tyr Ile Leu Ser Leu Leu Leu Gln Gly Tyr His Phe Thr Ala Asp  
 420 425 430

Ser Trp Glu His Ile His Phe Ile Gly Lys Ile Gln Gly Ser Asp Ala  
 435 440 445

Gly Trp Thr Leu Gly Tyr Met Leu Asn Leu Thr Asn Met Ile Pro Ala  
 450 455 460

Glu Gln Pro Leu Ser Thr Pro Leu Ser His Ser Thr  
 465 470 475

<210> 4

<211> 476

<212> PRT

<213> Artificial Sequence

<220>

<223> Description of Artificial Sequence: Fusion  
 construct of human CD39

<220>

<221> VARIANT

<222> (39)

<223> Any amino acid, preferably Cys or Ser

<400> 4

Met Ala Thr Ser Trp Gly Thr Val Phe Phe Met Leu Val Val Ser Cys  
 1 5 10 15

Val Cys Ser Ala Val Ser His Arg Asn Gln Gln Thr Trp Phe Glu Gly  
 20 25 30

Ile Phe Leu Ser Ser Met Xaa Pro Ile Asn Val Ser Ala Ser Thr Leu  
 35 40 45

Tyr Gly Ile Val Leu Asp Ala Gly Ser Ser His Thr Ser Leu Tyr Ile  
 50 55 60

Tyr Lys Trp Pro Ala Glu Lys Glu Asn Asp Thr Gly Val Val His Gln  
 65 70 75 80

Val Glu Glu Cys Arg Val Lys Gly Pro Gly Ile Ser Lys Phe Val Gln  
 85 90 95

Lys Val Asn Glu Ile Gly Ile Tyr Leu Thr Asp Cys Met Glu Arg Ala  
 100 105 110

Arg Glu Val Ile Pro Arg Ser Gln His Gln Glu Thr Pro Val Tyr Leu  
 115 120 125

Gly Ala Thr Ala Gly Met Arg Leu Leu Arg Met Glu Ser Glu Glu Leu  
 130 135 140

Ala Asp Arg Val Leu Asp Val Val Glu Arg Ser Leu Ser Asn Tyr Pro  
 145 150 155 160

Phe Asp Phe Gln Gly Ala Arg Ile Ile Thr Gly Gln Glu Glu Gly Ala  
 165 170 175

Tyr Gly Trp Ile Thr Ile Asn Tyr Leu Leu Gly Lys Phe Ser Gln Lys  
 180 185 190

Thr Arg Trp Phe Ser Ile Val Pro Tyr Glu Thr Asn Asn Gln Glu Thr  
 195 200 205

Phe Gly Ala Leu Asp Leu Gly Gly Ala Ser Thr Gln Val Thr Phe Val  
 210 215 220

Pro Gln Asn Gln Thr Ile Glu Ser Pro Asp Asn Ala Leu Gln Phe Arg  
 225 230 235 240

Leu Tyr Gly Lys Asp Tyr Asn Val Tyr Thr His Ser Phe Leu Cys Tyr  
 245 250 255

Gly Lys Asp Gln Ala Leu Trp Gln Lys Leu Ala Lys Asp Ile Gln Val  
 260 265 270

Ala Ser Asn Glu Ile Leu Arg Asp Pro Cys Phe His Pro Gly Tyr Lys  
 275 280 285

Lys Val Val Asn Val Ser Asp Leu Tyr Lys Thr Pro Cys Thr Lys Arg  
 290 295 300

Phe Glu Met Thr Leu Pro Phe Gln Gln Phe Glu Ile Gln Gly Ile Gly  
 305 310 315 320

Asn Tyr Gln Gln Cys His Gln Ser Ile Leu Glu Leu Phe Asn Thr Ser  
 325 330 335

Tyr Cys Pro Tyr Ser Gln Cys Ala Phe Asn Gly Ile Phe Leu Pro Pro  
 340 345 350

Leu Gln Gly Asp Phe Gly Ala Phe Ser Ala Phe Tyr Phe Val Met Lys  
 355 360 365

Phe Leu Asn Leu Thr Ser Glu Lys Val Ser Gln Glu Lys Val Thr Glu  
 370 375 380

Met Met Lys Lys Phe Cys Ala Gln Pro Trp Glu Glu Ile Lys Thr Ser  
 385 390 395 400

Tyr Ala Gly Val Lys Glu Lys Tyr Leu Ser Glu Tyr Cys Phe Ser Gly  
 405 410 415

Thr Tyr Ile Leu Ser Leu Leu Leu Gln Gly Tyr His Phe Thr Ala Asp  
 420 425 430

Ser Trp Glu His Ile His Phe Ile Gly Lys Ile Gln Gly Ser Asp Ala  
 435 440 445

Gly Trp Thr Leu Gly Tyr Met Leu Asn Leu Thr Asn Met Ile Pro Ala  
 450 455 460

Glu Gln Pro Leu Ser Thr Pro Leu Ser His Ser Thr  
 465 470 475

<210> 5  
 <211> 1365  
 <212> DNA  
 <213> Artificial Sequence

<220>  
 <223> Description of Artificial Sequence: Fusion  
 construct of human CD39

<220>  
 <221> CDS  
 <222> (1)..(1362)

<400> 5  
 gca cct act tca agt tct aca aag aaa aca cag cta act agt tca acc 48  
 Ala Pro Thr Ser Ser Ser Thr Lys Lys Thr Gln Leu Thr Ser Ser Thr  
 1 5 10 15

cag aac aaa gca ttg cca gaa aac gtt aag tat ggg att gtg ctg gat 96  
 Gln Asn Lys Ala Leu Pro Glu Asn Val Lys Tyr Gly Ile Val Leu Asp  
 20 25 30

gcg ggt tct tct cac aca agt tta tac atc tat aag tgg cca gca gaa 144  
 Ala Gly Ser Ser His Thr Ser Leu Tyr Ile Tyr Lys Trp Pro Ala Glu  
 35 40 45

aag gag aat gac aca ggc gtg gtg cat caa gta gaa gaa tgc agg gtt 192  
 Lys Glu Asn Asp Thr Gly Val Val His Gln Val Glu Glu Cys Arg Val  
 50 55 60

aaa ggt cct gga atc tca aaa ttt gtt cag aaa gta aat gaa ata ggc 240  
 Lys Gly Pro Gly Ile Ser Lys Phe Val Gln Lys Val Asn Glu Ile Gly  
 65 70 75 80

att tac ctg act gat tgc atg gaa aga gct agg gaa gtg att cca agg 288  
 Ile Tyr Leu Thr Asp Cys Met Glu Arg Ala Arg Glu Val Ile Pro Arg  
 85 90 95

tcc cag cac caa gag aca ccc gtt tac ctg gga gcc acg gca ggc atg 336

Ser	Gln	His	Gln	Glu	Thr	Pro	Val	Tyr	Leu	Gly	Ala	Thr	Ala	Gly	Met	
			100					105						110		
cgg	ttg	ctc	agg	atg	gaa	agt	gaa	gag	ttg	gca	gac	agg	gtt	ctg	gat	384
Arg	Leu	Leu	Arg	Met	Glu	Ser	Glu	Glu	Leu	Ala	Asp	Arg	Val	Leu	Asp	
		115					120					125				
gtg	gtg	gag	agg	agc	ctc	agc	aac	tac	ccc	ttt	gac	ttc	cag	ggt	gcc	432
Val	Val	Glu	Arg	Ser	Leu	Ser	Asn	Tyr	Pro	Phe	Asp	Phe	Gln	Gly	Ala	
		130				135					140					
agg	atc	att	act	ggc	caa	gag	gaa	ggt	gcc	tat	ggc	tgg	att	act	atc	480
Arg	Ile	Ile	Thr	Gly	Gln	Glu	Glu	Gly	Ala	Tyr	Gly	Trp	Ile	Thr	Ile	
	145				150					155					160	
aac	tat	ctg	ctg	ggc	aaa	ttc	agt	cag	aaa	aca	agg	tgg	ttc	agc	ata	528
Asn	Tyr	Leu	Leu	Gly	Lys	Phe	Ser	Gln	Lys	Thr	Arg	Trp	Phe	Ser	Ile	
				165					170					175		
gtc	cca	tat	gaa	acc	aat	aat	cag	gaa	acc	ttt	gga	gct	ttg	gac	ctt	576
Val	Pro	Tyr	Glu	Thr	Asn	Asn	Gln	Glu	Thr	Phe	Gly	Ala	Leu	Asp	Leu	
			180					185						190		
ggg	gga	gcc	tct	aca	caa	gtc	act	ttt	gta	ccc	caa	aac	cag	act	atc	624
Gly	Gly	Ala	Ser	Thr	Gln	Val	Thr	Phe	Val	Pro	Gln	Asn	Gln	Thr	Ile	
		195				200						205				
gag	tcc	cca	gat	aat	gct	ctg	caa	ttt	cgc	ctc	tat	ggc	aag	gac	tac	672
Glu	Ser	Pro	Asp	Asn	Ala	Leu	Gln	Phe	Arg	Leu	Tyr	Gly	Lys	Asp	Tyr	
		210				215					220					
aat	gtc	tac	aca	cat	agc	ttc	ttg	tgc	tat	ggg	aag	gat	cag	gca	ctc	720
Asn	Val	Tyr	Thr	His	Ser	Phe	Leu	Cys	Tyr	Gly	Lys	Asp	Gln	Ala	Leu	
	225				230					235					240	
tgg	cag	aaa	ctg	gcc	aag	gac	att	cag	gtt	gca	agt	aat	gaa	att	ctc	768
Trp	Gln	Lys	Leu	Ala	Lys	Asp	Ile	Gln	Val	Ala	Ser	Asn	Glu	Ile	Leu	
				245					250					255		
agg	gac	cca	tgc	ttt	cat	cct	gga	tat	aag	aag	gta	gtg	aac	gta	agt	816
Arg	Asp	Pro	Cys	Phe	His	Pro	Gly	Tyr	Lys	Lys	Val	Val	Asn	Val	Ser	
			260					265					270			
gac	ctt	tac	aag	acc	ccc	tgc	acc	aag	aga	ttt	gag	atg	act	ctt	cca	864
Asp	Leu	Tyr	Lys	Thr	Pro	Cys	Thr	Lys	Arg	Phe	Glu	Met	Thr	Leu	Pro	
		275					280					285				
ttc	cag	cag	ttt	gaa	atc	cag	ggt	att	gga	aac	tat	caa	caa	tgc	cat	912
Phe	Gln	Gln	Phe	Glu	Ile	Gln	Gly	Ile	Gly	Asn	Tyr	Gln	Gln	Cys	His	
			290			295					300					
caa	agc	atc	ctg	gag	ctc	ttc	aac	acc	agt	tac	tgc	cct	tac	tcc	cag	960
Gln	Ser	Ile	Leu	Glu	Leu	Phe	Asn	Thr	Ser	Tyr	Cys	Pro	Tyr	Ser	Gln	
			305			310				315					320	
tgt	gcc	ttc	aat	ggg	att	ttc	ttg	cca	cca	ctc	cag	ggg	gat	ttt	ggg	1008
Cys	Ala	Phe	Asn	Gly	Ile	Phe	Leu	Pro	Pro	Leu	Gln	Gly	Asp	Phe	Gly	
				325					330					335		

gca ttt tca gct ttt tac ttt gtg atg aag ttt tta aac ttg aca tca 1056  
 Ala Phe Ser Ala Phe Tyr Phe Val Met Lys Phe Leu Asn Leu Thr Ser  
 340 345 350

gag aaa gtc tct cag gaa aag gtg act gag atg atg aaa aag ttc tgt 1104  
 Glu Lys Val Ser Gln Glu Lys Val Thr Glu Met Met Lys Lys Phe Cys  
 355 360 365

gct cag cct tgg gag gag ata aaa aca tct tac gct gga gta aag gag 1152  
 Ala Gln Pro Trp Glu Glu Ile Lys Thr Ser Tyr Ala Gly Val Lys Glu  
 370 375 380

aag tac ctg agt gaa tac tgc ttt tct ggt acc tac att ctc tcc ctc 1200  
 Lys Tyr Leu Ser Glu Tyr Cys Phe Ser Gly Thr Tyr Ile Leu Ser Leu  
 385 390 395 400

ctt ctg caa ggc tat cat ttc aca gct gat tcc tgg gag cac atc cat 1248  
 Leu Leu Gln Gly Tyr His Phe Thr Ala Asp Ser Trp Glu His Ile His  
 405 410 415

ttc att ggc aag atc cag ggc agc gac gcc ggc tgg act ttg ggc tac 1296  
 Phe Ile Gly Lys Ile Gln Gly Ser Asp Ala Gly Trp Thr Leu Gly Tyr  
 420 425 430

atg ctg aac ctg acc aac atg atc cca gct gag caa cca ttg tcc aca 1344  
 Met Leu Asn Leu Thr Asn Met Ile Pro Ala Glu Gln Pro Leu Ser Thr  
 435 440 445

cct ctc tcc cac tcc acc taa 1365  
 Pro Leu Ser His Ser Thr  
 450

<210> 6  
 <211> 454  
 <212> PRT  
 <213> Artificial Sequence

<400> 6  
 Ala Pro Thr Ser Ser Ser Thr Lys Lys Thr Gln Leu Thr Ser Ser Thr  
 1 5 10 15  
 Gln Asn Lys Ala Leu Pro Glu Asn Val Lys Tyr Gly Ile Val Leu Asp  
 20 25 30  
 Ala Gly Ser Ser His Thr Ser Leu Tyr Ile Tyr Lys Trp Pro Ala Glu  
 35 40 45  
 Lys Glu Asn Asp Thr Gly Val Val His Gln Val Glu Glu Cys Arg Val  
 50 55 60  
 Lys Gly Pro Gly Ile Ser Lys Phe Val Gln Lys Val Asn Glu Ile Gly  
 65 70 75 80  
 Ile Tyr Leu Thr Asp Cys Met Glu Arg Ala Arg Glu Val Ile Pro Arg  
 85 90 95

Ser Gln His Gln Glu Thr Pro Val Tyr Leu Gly Ala Thr Ala Gly Met  
 100 105 110

Arg Leu Leu Arg Met Glu Ser Glu Glu Leu Ala Asp Arg Val Leu Asp  
 115 120 125

Val Val Glu Arg Ser Leu Ser Asn Tyr Pro Phe Asp Phe Gln Gly Ala  
 130 135 140

Arg Ile Ile Thr Gly Gln Glu Glu Gly Ala Tyr Gly Trp Ile Thr Ile  
 145 150 155 160

Asn Tyr Leu Leu Gly Lys Phe Ser Gln Lys Thr Arg Trp Phe Ser Ile  
 165 170 175

Val Pro Tyr Glu Thr Asn Asn Gln Glu Thr Phe Gly Ala Leu Asp Leu  
 180 185 190

Gly Gly Ala Ser Thr Gln Val Thr Phe Val Pro Gln Asn Gln Thr Ile  
 195 200 205

Glu Ser Pro Asp Asn Ala Leu Gln Phe Arg Leu Tyr Gly Lys Asp Tyr  
 210 215 220

Asn Val Tyr Thr His Ser Phe Leu Cys Tyr Gly Lys Asp Gln Ala Leu  
 225 230 235 240

Trp Gln Lys Leu Ala Lys Asp Ile Gln Val Ala Ser Asn Glu Ile Leu  
 245 250 255

Arg Asp Pro Cys Phe His Pro Gly Tyr Lys Lys Val Val Asn Val Ser  
 260 265 270

Asp Leu Tyr Lys Thr Pro Cys Thr Lys Arg Phe Glu Met Thr Leu Pro  
 275 280 285

Phe Gln Gln Phe Glu Ile Gln Gly Ile Gly Asn Tyr Gln Gln Cys His  
 290 295 300

Gln Ser Ile Leu Glu Leu Phe Asn Thr Ser Tyr Cys Pro Tyr Ser Gln  
 305 310 315 320

Cys Ala Phe Asn Gly Ile Phe Leu Pro Pro Leu Gln Gly Asp Phe Gly  
 325 330 335

Ala Phe Ser Ala Phe Tyr Phe Val Met Lys Phe Leu Asn Leu Thr Ser  
 340 345 350

Glu Lys Val Ser Gln Glu Lys Val Thr Glu Met Met Lys Lys Phe Cys  
 355 360 365

Ala Gln Pro Trp Glu Glu Ile Lys Thr Ser Tyr Ala Gly Val Lys Glu  
 370 375 380

Lys Tyr Leu Ser Glu Tyr Cys Phe Ser Gly Thr Tyr Ile Leu Ser Leu  
 385 390 395 400



Leu Leu Gln Gly Tyr His Phe Thr Ala Asp Ser Trp Glu His Ile His  
 405 410 415

Phe Ile Gly Lys Ile Gln Gly Ser Asp Ala Gly Trp Thr Leu Gly Tyr  
 420 425 430

Met Leu Asn Leu Thr Asn Met Ile Pro Ala Glu Gln Pro Leu Ser Thr  
 435 440 445

Pro Leu Ser His Ser Thr  
 450

<210> 7  
 <211> 1437  
 <212> DNA  
 <213> Artificial Sequence

<220>  
 <223> Description of Artificial Sequence: Fusion  
 construct of human CD39

<220>  
 <221> CDS  
 <222> (1)..(1434)

<400> 7  
 atg gcc ctg tgg atc gac agg atg caa ctc ctg tct tgc att gca cta 48  
 Met Ala Leu Trp Ile Asp Arg Met Gln Leu Leu Ser Cys Ile Ala Leu  
 1 5 10 15

agt ctt gca ctt gtc aca aac agt gca cct act tca agt tct aca aag 96  
 Ser Leu Ala Leu Val Thr Asn Ser Ala Pro Thr Ser Ser Ser Thr Lys  
 20 25 30

aaa aca cag cta act agt tca acc cag aac aaa gca ttg cca gaa aac 144  
 Lys Thr Gln Leu Thr Ser Ser Thr Gln Asn Lys Ala Leu Pro Glu Asn  
 35 40 45

gtt aag tat ggg att gtg ctg gat gcg ggt tct tct cac aca agt tta 192  
 Val Lys Tyr Gly Ile Val Leu Asp Ala Gly Ser Ser His Thr Ser Leu  
 50 55 60

tac atc tat aag tgg cca gca gaa aag gag aat gac aca ggc gtg gtg 240  
 Tyr Ile Tyr Lys Trp Pro Ala Glu Lys Glu Asn Asp Thr Gly Val Val  
 65 70 75 80

cat caa gta gaa gaa tgc agg gtt aaa ggt cct gga atc tca aaa ttt 288  
 His Gln Val Glu Glu Cys Arg Val Lys Gly Pro Gly Ile Ser Lys Phe  
 85 90 95

gtt cag aaa gta aat gaa ata ggc att tac ctg act gat tgc atg gaa 336  
 Val Gln Lys Val Asn Glu Ile Gly Ile Tyr Leu Thr Asp Cys Met Glu  
 100 105 110

aga gct agg gaa gtg att cca agg tcc cag cac caa gag aca ccc gtt 384  
 Arg Ala Arg Glu Val Ile Pro Arg Ser Gln His Gln Glu Thr Pro Val  
 115 120 125

tac ctg gga gcc acg gca ggc atg cgg ttg ctc agg atg gaa agt gaa 432  
 Tyr Leu Gly Ala Thr Ala Gly Met Arg Leu Leu Arg Met Glu Ser Glu  
 130 135 140

gag ttg gca gac agg gtt ctg gat gtg gtg gag agg agc ctc agc aac 480  
 Glu Leu Ala Asp Arg Val Leu Asp Val Val Glu Arg Ser Leu Ser Asn  
 145 150 155 160

tac ccc ttt gac ttc cag ggt gcc agg atc att act ggc caa gag gaa 528  
 Tyr Pro Phe Asp Phe Gln Gly Ala Arg Ile Ile Thr Gly Gln Glu Glu  
 165 170 175

ggt gcc tat ggc tgg att act atc aac tat ctg ctg ggc aaa ttc agt 576  
 Gly Ala Tyr Gly Trp Ile Thr Ile Asn Tyr Leu Leu Gly Lys Phe Ser  
 180 185 190

cag aaa aca agg tgg ttc agc ata gtc cca tat gaa acc aat aat cag 624  
 Gln Lys Thr Arg Trp Phe Ser Ile Val Pro Tyr Glu Thr Asn Asn Gln  
 195 200 205

gaa acc ttt gga gct ttg gac ctt ggg gga gcc tct aca caa gtc act 672  
 Glu Thr Phe Gly Ala Leu Asp Leu Gly Gly Ala Ser Thr Gln Val Thr  
 210 215 220

ttt gta ccc caa aac cag act atc gag tcc cca gat aat gct ctg caa 720  
 Phe Val Pro Gln Asn Gln Thr Ile Glu Ser Pro Asp Asn Ala Leu Gln  
 225 230 235 240

ttt cgc ctc tat ggc aag gac tac aat gtc tac aca cat agc ttc ttg 768  
 Phe Arg Leu Tyr Gly Lys Asp Tyr Asn Val Tyr Thr His Ser Phe Leu  
 245 250 255

tgc tat ggg aag gat cag gca ctc tgg cag aaa ctg gcc aag gac att 816  
 Cys Tyr Gly Lys Asp Gln Ala Leu Trp Gln Lys Leu Ala Lys Asp Ile  
 260 265 270

cag gtt gca agt aat gaa att ctc agg gac cca tgc ttt cat cct gga 864  
 Gln Val Ala Ser Asn Glu Ile Leu Arg Asp Pro Cys Phe His Pro Gly  
 275 280 285

tat aag aag gta gtg aac gta agt gac ctt tac aag acc ccc tgc acc 912  
 Tyr Lys Lys Val Val Asn Val Ser Asp Leu Tyr Lys Thr Pro Cys Thr  
 290 295 300

aag aga ttt gag atg act ctt cca ttc cag cag ttt gaa atc cag ggt 960  
 Lys Arg Phe Glu Met Thr Leu Pro Phe Gln Gln Phe Glu Ile Gln Gly  
 305 310 315 320

att gga aac tat caa caa tgc cat caa agc atc ctg gag ctc ttc aac 1008  
 Ile Gly Asn Tyr Gln Gln Cys His Gln Ser Ile Leu Glu Leu Phe Asn  
 325 330 335

acc agt tac tgc cct tac tcc cag tgt gcc ttc aat ggg att ttc ttg 1056  
 Thr Ser Tyr Cys Pro Tyr Ser Gln Cys Ala Phe Asn Gly Ile Phe Leu  
 340 345 350

cca cca ctc cag ggg gat ttt ggg gca ttt tca gct ttt tac ttt gtg 1104

Pro Pro Leu Gln Gly Asp Phe Gly Ala Phe Ser Ala Phe Tyr Phe Val  
 355 360 365

atg aag ttt tta aac ttg aca tca gag aaa gtc tct cag gaa aag gtg 1152  
 Met Lys Phe Leu Asn Leu Thr Ser Glu Lys Val Ser Gln Glu Lys Val  
 370 375 380

act gag atg atg aaa aag ttc tgt gct cag cct tgg gag gag ata aaa 1200  
 Thr Glu Met Met Lys Lys Phe Cys Ala Gln Pro Trp Glu Glu Ile Lys  
 385 390 395 400

aca tct tac gct gga gta aag gag aag tac ctg agt gaa tac tgc ttt 1248  
 Thr Ser Tyr Ala Gly Val Lys Glu Lys Tyr Leu Ser Glu Tyr Cys Phe  
 405 410 415

tct ggt acc tac att ctc tcc ctc ctt ctg caa ggc tat cat ttc aca 1296  
 Ser Gly Thr Tyr Ile Leu Ser Leu Leu Leu Gln Gly Tyr His Phe Thr  
 420 425 430

gct gat tcc tgg gag cac atc cat ttc att ggc aag atc cag ggc agc 1344  
 Ala Asp Ser Trp Glu His Ile His Phe Ile Gly Lys Ile Gln Gly Ser  
 435 440 445

gac gcc ggc tgg act ttg ggc tac atg ctg aac ctg acc aac atg atc 1392  
 Asp Ala Gly Trp Thr Leu Gly Tyr Met Leu Asn Leu Thr Asn Met Ile  
 450 455 460

cca gct gag caa cca ttg tcc aca cct ctc tcc cac tcc acc taa 1437  
 Pro Ala Glu Gln Pro Leu Ser Thr Pro Leu Ser His Ser Thr  
 465 470 475

<210> 8  
 <211> 478  
 <212> PRT  
 <213> Artificial Sequence

<400> 8  
 Met Ala Leu Trp Ile Asp Arg Met Gln Leu Leu Ser Cys Ile Ala Leu  
 1 5 10 15

Ser Leu Ala Leu Val Thr Asn Ser Ala Pro Thr Ser Ser Ser Thr Lys  
 20 25 30

Lys Thr Gln Leu Thr Ser Ser Thr Gln Asn Lys Ala Leu Pro Glu Asn  
 35 40 45

Val Lys Tyr Gly Ile Val Leu Asp Ala Gly Ser Ser His Thr Ser Leu  
 50 55 60

Tyr Ile Tyr Lys Trp Pro Ala Glu Lys Glu Asn Asp Thr Gly Val Val  
 65 70 75 80

His Gln Val Glu Glu Cys Arg Val Lys Gly Pro Gly Ile Ser Lys Phe  
 85 90 95

Val Gln Lys Val Asn Glu Ile Gly Ile Tyr Leu Thr Asp Cys Met Glu  
 100 105 110

Arg Ala Arg Glu Val Ile Pro Arg Ser Gln His Gln Glu Thr Pro Val  
 115 120 125

Tyr Leu Gly Ala Thr Ala Gly Met Arg Leu Leu Arg Met Glu Ser Glu  
 130 135 140

Glu Leu Ala Asp Arg Val Leu Asp Val Val Glu Arg Ser Leu Ser Asn  
 145 150 155 160

Tyr Pro Phe Asp Phe Gln Gly Ala Arg Ile Ile Thr Gly Gln Glu Glu  
 165 170 175

Gly Ala Tyr Gly Trp Ile Thr Ile Asn Tyr Leu Leu Gly Lys Phe Ser  
 180 185 190

Gln Lys Thr Arg Trp Phe Ser Ile Val Pro Tyr Glu Thr Asn Asn Gln  
 195 200 205

Glu Thr Phe Gly Ala Leu Asp Leu Gly Gly Ala Ser Thr Gln Val Thr  
 210 215 220

Phe Val Pro Gln Asn Gln Thr Ile Glu Ser Pro Asp Asn Ala Leu Gln  
 225 230 235 240

Phe Arg Leu Tyr Gly Lys Asp Tyr Asn Val Tyr Thr His Ser Phe Leu  
 245 250 255

Cys Tyr Gly Lys Asp Gln Ala Leu Trp Gln Lys Leu Ala Lys Asp Ile  
 260 265 270

Gln Val Ala Ser Asn Glu Ile Leu Arg Asp Pro Cys Phe His Pro Gly  
 275 280 285

Tyr Lys Lys Val Val Asn Val Ser Asp Leu Tyr Lys Thr Pro Cys Thr  
 290 295 300

Lys Arg Phe Glu Met Thr Leu Pro Phe Gln Gln Phe Glu Ile Gln Gly  
 305 310 315 320

Ile Gly Asn Tyr Gln Gln Cys His Gln Ser Ile Leu Glu Leu Phe Asn  
 325 330 335

Thr Ser Tyr Cys Pro Tyr Ser Gln Cys Ala Phe Asn Gly Ile Phe Leu  
 340 345 350

Pro Pro Leu Gln Gly Asp Phe Gly Ala Phe Ser Ala Phe Tyr Phe Val  
 355 360 365

Met Lys Phe Leu Asn Leu Thr Ser Glu Lys Val Ser Gln Glu Lys Val  
 370 375 380

Thr Glu Met Met Lys Lys Phe Cys Ala Gln Pro Trp Glu Glu Ile Lys  
 385 390 395 400

Thr Ser Tyr Ala Gly Val Lys Glu Lys Tyr Leu Ser Glu Tyr Cys Phe  
 405 410 415

Ser Gly Thr Tyr Ile Leu Ser Leu Leu Leu Gln Gly Tyr His Phe Thr  
 420 425 430

Ala Asp Ser Trp Glu His Ile His Phe Ile Gly Lys Ile Gln Gly Ser  
 435 440 445

Asp Ala Gly Trp Thr Leu Gly Tyr Met Leu Asn Leu Thr Asn Met Ile  
 450 455 460

Pro Ala Glu Gln Pro Leu Ser Thr Pro Leu Ser His Ser Thr  
 465 470 475

<210> 9  
 <211> 24  
 <212> PRT  
 <213> Artificial Sequence

<220>  
 <223> Description of Artificial Sequence: Synthetic  
 signal sequence

<400> 9  
 Met Ala Leu Trp Ile Asp Arg Met Gln Leu Leu Ser Cys Ile Ala Leu  
 1 5 10 15

Ser Leu Ala Leu Val Thr Asn Ser  
 20

<210> 10  
 <211> 8  
 <212> PRT  
 <213> Artificial Sequence

<220>  
 <223> Description of Artificial Sequence: Synthetic  
 peptide

<400> 10  
 Asp Tyr Lys Asp Asp Asp Asp Lys  
 1 5

<210> 11  
 <211> 43  
 <212> PRT  
 <213> Artificial Sequence

<220>  
 <223> Description of Artificial Sequence: Fusion  
 construct of human CD39

<400> 11  
 Met Ala Leu Trp Ile Asp Arg Met Gln Leu Leu Ser Cys Ile Ala Leu  
 1 5 10 15

Ser Leu Ala Leu Val Thr Asn Ser Ala Pro Thr Ser Ser Ser Thr Lys  
20 25 30

Lys Thr Gln Leu Thr Ser Ser Thr Gln Asn Lys  
35 40

<210> 12  
<211> 29  
<212> PRT  
<213> Artificial Sequence

<220>  
<223> Description of Artificial Sequence: Fusion  
construct of human CD39

<400> 12  
Met Ala Leu Trp Ile Asp Arg Met Gln Leu Leu Ser Cys Ile Ala Leu  
1 5 10 15

Ser Leu Ala Leu Val Thr Asn Ser Ala Thr Gln Asn Lys  
20 25

<210> 13  
<211> 31  
<212> PRT  
<213> Artificial Sequence

<220>  
<223> Description of Artificial Sequence: Fusion  
construct of human CD39

<400> 13  
Met Ala Leu Trp Ile Asp Arg Met Gln Leu Leu Ser Cys Ile Ala Leu  
1 5 10 15

Ser Leu Ala Leu Val Thr Asn Ser Ala Ser Ser Thr Gln Asn Lys  
20 25 30

<210> 14  
<211> 87  
<212> DNA  
<213> Artificial Sequence

<220>  
<223> Description of Artificial Sequence: Synthetic  
oligonucleotide

<400> 14  
ccggctggac tttgggctac atgctgaacc tgaccaacat gatcccagct gagcaaccat 60  
tgtccacacc tctctcccac gagcccc 87

<210> 15  
<211> 87

<212> DNA  
 <213> Artificial Sequence

<220>  
 <223> Description of Artificial Sequence: Synthetic oligonucleotide

<400> 15  
 gatcggggct cgtgggagag aggtgtggac aatggttgct cagctgggat catgttggtc 60  
 aggttcagca tntagcccaa agtccag 87

<210> 16  
 <211> 740  
 <212> DNA  
 <213> Homo sapiens

<220>  
 <221> CDS  
 <222> (42)..(737)

<400> 16  
 cggtagcgct agcgtcgaca ggcctaggat atcgatacgt a gag ccc aga tct tgt 56  
 Glu Pro Arg Ser Cys  
 1 5

gac aaa act cac aca tgc cca ccg tgc cca gca cct gaa gcc gag ggc 104  
 Asp Lys Thr His Thr Cys Pro Pro Cys Pro Ala Pro Glu Ala Glu Gly  
 10 15 20

gcg ccg tca gtc ttc ctc ttc ccc cca aaa ccc aag gac acc ctc atg 152  
 Ala Pro Ser Val Phe Leu Phe Pro Pro Lys Pro Lys Asp Thr Leu Met  
 25 30 35

atc tcc cgg acc cct gag gtc aca tgc gtg gtg gtg gac gtg agc cac 200  
 Ile Ser Arg Thr Pro Glu Val Thr Cys Val Val Val Asp Val Ser His  
 40 45 50

gaa gac cct gag gtc aag ttc aac tgg tac gtg gac ggc gtg gag gtg 248  
 Glu Asp Pro Glu Val Lys Phe Asn Trp Tyr Val Asp Gly Val Glu Val  
 55 60 65

cat aat gcc aag aca aag ccg cgg gag gag cag tac aac agc acg tac 296  
 His Asn Ala Lys Thr Lys Pro Arg Glu Glu Gln Tyr Asn Ser Thr Tyr  
 70 75 80 85

cgg gtg gtc agc gtc ctc acc gtc ctg cac cag gac tgg ctg aat ggc 344  
 Arg Val Val Ser Val Leu Thr Val Leu His Gln Asp Trp Leu Asn Gly  
 90 95 100

aag gac tac aag tgc aag gtc tcc aac aaa gcc ctc cca gcc ccc atg 392  
 Lys Asp Tyr Lys Cys Lys Val Ser Asn Lys Ala Leu Pro Ala Pro Met  
 105 110 115

cag aaa acc atc tcc aaa gcc aaa ggg cag ccc cga gaa cca cag gtg 440  
 Gln Lys Thr Ile Ser Lys Ala Lys Gly Gln Pro Arg Glu Pro Gln Val  
 120 125 130

tac acc ctg ccc cca tcc cgg gat gag ctg acc aag aac cag gtc agc 488  
 Tyr Thr Leu Pro Pro Ser Arg Asp Glu Leu Thr Lys Asn Gln Val Ser  
 135 140 145

ctg acc tgc ctg gtc aaa ggc ttc tat ccc agg cac atc gcc gtg gag 536  
 Leu Thr Cys Leu Val Lys Gly Phe Tyr Pro Arg His Ile Ala Val Glu  
 150 155 160 165

tgg gag agc aat ggg cag ccg gag aac aac tac aag acc acg cct ccc 584  
 Trp Glu Ser Asn Gly Gln Pro Glu Asn Asn Tyr Lys Thr Thr Pro Pro  
 170 175 180

gtg ctg gac tcc gac ggc tcc ttc ttc ctc tac agc aag ctc acc gtg 632  
 Val Leu Asp Ser Asp Gly Ser Phe Phe Leu Tyr Ser Lys Leu Thr Val  
 185 190 195

gac aag agc agg tgg cag cag ggg aac gtc ttc tca tgc tcc gtg atg 680  
 Asp Lys Ser Arg Trp Gln Gln Gly Asn Val Phe Ser Cys Ser Val Met  
 200 205 210

cat gag gct ctg cac aac cac tac acg cag aag agc ctc tcc ctg tct 728  
 His Glu Ala Leu His Asn His Tyr Thr Gln Lys Ser Leu Ser Leu Ser  
 215 220 225

ccg ggt aaa tga 740  
 Pro Gly Lys  
 230

<210> 17  
 <211> 232  
 <212> PRT  
 <213> Homo sapiens

<400> 17  
 Glu Pro Arg Ser Cys Asp Lys Thr His Thr Cys Pro Pro Cys Pro Ala  
 1 5 10 15

Pro Glu Ala Glu Gly Ala Pro Ser Val Phe Leu Phe Pro Pro Lys Pro  
 20 25 30

Lys Asp Thr Leu Met Ile Ser Arg Thr Pro Glu Val Thr Cys Val Val  
 35 40 45

Val Asp Val Ser His Glu Asp Pro Glu Val Lys Phe Asn Trp Tyr Val  
 50 55 60

Asp Gly Val Glu Val His Asn Ala Lys Thr Lys Pro Arg Glu Glu Gln  
 65 70 75 80

Tyr Asn Ser Thr Tyr Arg Val Val Ser Val Leu Thr Val Leu His Gln  
 85 90 95

Asp Trp Leu Asn Gly Lys Asp Tyr Lys Cys Lys Val Ser Asn Lys Ala  
 100 105 110



Leu Pro Ala Pro Met Gln Lys Thr Ile Ser Lys Ala Lys Gly Gln Pro  
 115 120 125

Arg Glu Pro Gln Val Tyr Thr Leu Pro Pro Ser Arg Asp Glu Leu Thr  
 130 135 140

Lys Asn Gln Val Ser Leu Thr Cys Leu Val Lys Gly Phe Tyr Pro Arg  
 145 150 155 160

His Ile Ala Val Glu Trp Glu Ser Asn Gly Gln Pro Glu Asn Asn Tyr  
 165 170 175

Lys Thr Thr Pro Pro Val Leu Asp Ser Asp Gly Ser Phe Phe Leu Tyr  
 180 185 190

Ser Lys Leu Thr Val Asp Lys Ser Arg Trp Gln Gln Gly Asn Val Phe  
 195 200 205

Ser Cys Ser Val Met His Glu Ala Leu His Asn His Tyr Thr Gln Lys  
 210 215 220

Ser Leu Ser Leu Ser Pro Gly Lys  
 225 230

<210> 18  
 <211> 18  
 <212> DNA  
 <213> Artificial Sequence

<220>  
 <223> Description of Artificial Sequence: Synthetic oligonucleotide

<400> 18  
 ctttccatcc tgagcaac

18

<210> 19  
 <211> 36  
 <212> DNA  
 <213> Artificial Sequence

<220>  
 <223> Description of Artificial Sequence: Synthetic oligonucleotide

<400> 19  
 aaaaaactag tcagaacaaa gctttgccag aaaacg

36

<210> 20  
 <211> 24  
 <212> PRT  
 <213> Mus sp.

&lt;400&gt; 20

Met Phe His Val Ser Phe Arg Tyr Ile Phe Gly Ile Pro Pro Leu Ile  
 1 5 10 15

Leu Val Leu Leu Pro Val Thr Ser  
 20

&lt;210&gt; 21

&lt;211&gt; 46

&lt;212&gt; DNA

&lt;213&gt; Artificial Sequence

&lt;220&gt;

&lt;223&gt; Description of Artificial Sequence: Synthetic oligonucleotide

&lt;400&gt; 21

ctagttctgg agactacaaa gatgacgatg acaaaaccca gaacaa

46

&lt;210&gt; 22

&lt;211&gt; 46

&lt;212&gt; DNA

&lt;213&gt; Artificial Sequence

&lt;220&gt;

&lt;223&gt; Description of Artificial Sequence: Synthetic oligonucleotide

&lt;400&gt; 22

agctttgttc tgggttttgt catcgtcatc tttgtagtct ccagaa

46

&lt;210&gt; 23

&lt;211&gt; 89

&lt;212&gt; DNA

&lt;213&gt; Artificial Sequence

&lt;220&gt;

&lt;223&gt; Description of Artificial Sequence: Synthetic oligonucleotide

&lt;400&gt; 23

ccggctggac tttgggctac atgctgaacc tgaccaacat gatcccagct gagcaaccat 60

tgtccacacc tctctcccac tccacctaa

89

&lt;210&gt; 24

&lt;211&gt; 89

&lt;212&gt; DNA

&lt;213&gt; Artificial Sequence

&lt;220&gt;

&lt;223&gt; Description of Artificial Sequence: Synthetic oligonucleotide

<400> 24  
 ggccttaggt ggagtgggag agaggtgtgg acaatggttg ctcagctggg atcatgttgg 60  
 tcaggttcag catgtagccc aaagtccag 89

<210> 25  
 <211> 1464  
 <212> DNA  
 <213> Artificial Sequence

<220>  
 <221> CDS  
 <222> (1)..(1461)

<220>  
 <223> Description of Artificial Sequence: Fusion  
 construct of human CD39

<400> 25  
 atg gcc ctg tgg atc gac agg atg caa ctc ctg tct tgc att gca cta 48  
 Met Ala Leu Trp Ile Asp Arg Met Gln Leu Leu Ser Cys Ile Ala Leu  
 1 5 10 15  
 agt ctt gca ctt gtc aca aac agt gca cct act tca agt tct aca aag 96  
 Ser Leu Ala Leu Val Thr Asn Ser Ala Pro Thr Ser Ser Ser Thr Lys  
 20 25 30  
 aaa aca cag cta act agt tca gga gac tac aaa gat gac gat gac aaa 144  
 Lys Thr Gln Leu Thr Ser Ser Gly Asp Tyr Lys Asp Asp Asp Lys  
 35 40 45  
 acc cag aac aaa gca ttg cca gaa aac gtt aag tat ggg att gtg ctg 192  
 Thr Gln Asn Lys Ala Leu Pro Glu Asn Val Lys Tyr Gly Ile Val Leu  
 50 55 60  
 gat gcg ggt tct tct cac aca agt tta tac atc tat aag tgg cca gca 240  
 Asp Ala Gly Ser Ser His Thr Ser Leu Tyr Ile Tyr Lys Trp Pro Ala  
 65 70 75 80  
 gaa aag gag aat gac aca ggc gtg gtg cat caa gta gaa gaa tgc agg 288  
 Glu Lys Glu Asn Asp Thr Gly Val Val His Gln Val Glu Glu Cys Arg  
 85 90 95  
 gtt aaa ggt cct gga atc tca aaa ttt gtt cag aaa gta aat gaa ata 336  
 Val Lys Gly Pro Gly Ile Ser Lys Phe Val Gln Lys Val Asn Glu Ile  
 100 105 110  
 ggc att tac ctg act gat tgc atg gaa aga gct agg gaa gtg att cca 384  
 Gly Ile Tyr Leu Thr Asp Cys Met Glu Arg Ala Arg Glu Val Ile Pro  
 115 120 125  
 agg tcc cag cac caa gag aca ccc gtt tac ctg gga gcc acg gca ggc 432  
 Arg Ser Gln His Gln Glu Thr Pro Val Tyr Leu Gly Ala Thr Ala Gly  
 130 135 140  
 atg cgg ttg ctc agg atg gaa agt gaa gag ttg gca gac agg gtt ctg 480

Met Arg Leu Leu Arg Met Glu Ser Glu Glu Leu Ala Asp Arg Val Leu	
145	150 155 160
gat gtg gtg gag agg agc ctc agc aac tac ccc ttt gac ttc cag ggt	528
Asp Val Val Glu Arg Ser Leu Ser Asn Tyr Pro Phe Asp Phe Gln Gly	165 170 175
gcc agg atc att act ggc caa gag gaa ggt gcc tat ggc tgg att act	576
Ala Arg Ile Ile Thr Gly Gln Glu Glu Gly Ala Tyr Gly Trp Ile Thr	180 185 190
atc aac tat ctg ctg ggc aaa ttc agt cag aaa aca agg tgg ttc agc	624
Ile Asn Tyr Leu Leu Gly Lys Phe Ser Gln Lys Thr Arg Trp Phe Ser	195 200 205
ata gtc cca tat gaa acc aat aat cag gaa acc ttt gga gct ttg gac	672
Ile Val Pro Tyr Glu Thr Asn Asn Gln Glu Thr Phe Gly Ala Leu Asp	210 215 220
ctt ggg gga gcc tct aca caa gtc act ttt gta ccc caa aac cag act	720
Leu Gly Gly Ala Ser Thr Gln Val Thr Phe Val Pro Gln Asn Gln Thr	225 230 235 240
atc gag tcc cca gat aat gct ctg caa ttt cgc ctc tat ggc aag gac	768
Ile Glu Ser Pro Asp Asn Ala Leu Gln Phe Arg Leu Tyr Gly Lys Asp	245 250 255
tac aat gtc tac aca cat agc ttc ttg tgc tat ggg aag gat cag gca	816
Tyr Asn Val Tyr Thr His Ser Phe Leu Cys Tyr Gly Lys Asp Gln Ala	260 265 270
ctc tgg cag aaa ctg gcc aag gac att cag gtt gca agt aat gaa att	864
Leu Trp Gln Lys Leu Ala Lys Asp Ile Gln Val Ala Ser Asn Glu Ile	275 280 285
ctc agg gac cca tgc ttt cat cct gga tat aag aag gta gtg aac gta	912
Leu Arg Asp Pro Cys Phe His Pro Gly Tyr Lys Lys Val Val Asn Val	290 295 300
agt gac ctt tac aag acc ccc tgc acc aag aga ttt gag atg act ctt	960
Ser Asp Leu Tyr Lys Thr Pro Cys Thr Lys Arg Phe Glu Met Thr Leu	305 310 315 320
cca ttc cag cag ttt gaa atc cag ggt att gga aac tat caa caa tgc	1008
Pro Phe Gln Gln Phe Glu Ile Gln Gly Ile Gly Asn Tyr Gln Gln Cys	325 330 335
cat caa agc atc ctg gag ctc ttc aac acc agt tac tgc cct tac tcc	1056
His Gln Ser Ile Leu Glu Leu Phe Asn Thr Ser Tyr Cys Pro Tyr Ser	340 345 350
cag tgt gcc ttc aat ggg att ttc ttg cca cca ctc cag ggg gat ttt	1104
Gln Cys Ala Phe Asn Gly Ile Phe Leu Pro Pro Leu Gln Gly Asp Phe	355 360 365
ggg gca ttt tca gct ttt tac ttt gtg atg aag ttt tta aac ttg aca	1152
Gly Ala Phe Ser Ala Phe Tyr Phe Val Met Lys Phe Leu Asn Leu Thr	370 375 380

tca gag aaa gtc tct cag gaa aag gtg act gag atg atg aaa aag ttc 1200  
 Ser Glu Lys Val Ser Gln Glu Lys Val Thr Glu Met Met Lys Lys Phe  
 385 390 395 400

tgt gct cag cct tgg gag gag ata aaa aca tct tac gct gga gta aag 1248  
 Cys Ala Gln Pro Trp Glu Glu Ile Lys Thr Ser Tyr Ala Gly Val Lys  
 405 410 415

gag aag tac ctg agt gaa tac tgc ttt tct ggt acc tac att ctc tcc 1296  
 Glu Lys Tyr Leu Ser Glu Tyr Cys Phe Ser Gly Thr Tyr Ile Leu Ser  
 420 425 430

ctc ctt ctg caa ggc tat cat ttc aca gct gat tcc tgg gag cac atc 1344  
 Leu Leu Gln Gly Tyr His Phe Thr Ala Asp Ser Trp Glu His Ile  
 435 440 445

cat ttc att ggc aag atc cag ggc agc gac gcc ggc tgg act ttg ggc 1392  
 His Phe Ile Gly Lys Ile Gln Gly Ser Asp Ala Gly Trp Thr Leu Gly  
 450 455 460

tac atg ctg aac ctg acc aac atg atc cca gct gag caa cca ttg tcc 1440  
 Tyr Met Leu Asn Leu Thr Asn Met Ile Pro Ala Glu Gln Pro Leu Ser  
 465 470 475 480

aca cct ctc tcc cac tcc acc taa 1464  
 Thr Pro Leu Ser His Ser Thr  
 485

<210> 26  
 <211> 487  
 <212> PRT  
 <213> Artificial Sequence

<400> 26  
 Met Ala Leu Trp Ile Asp Arg Met Gln Leu Leu Ser Cys Ile Ala Leu  
 1 5 10 15

Ser Leu Ala Leu Val Thr Asn Ser Ala Pro Thr Ser Ser Ser Thr Lys  
 20 25 30

Lys Thr Gln Leu Thr Ser Ser Gly Asp Tyr Lys Asp Asp Asp Asp Lys  
 35 40 45

Thr Gln Asn Lys Ala Leu Pro Glu Asn Val Lys Tyr Gly Ile Val Leu  
 50 55 60

Asp Ala Gly Ser Ser His Thr Ser Leu Tyr Ile Tyr Lys Trp Pro Ala  
 65 70 75 80

Glu Lys Glu Asn Asp Thr Gly Val Val His Gln Val Glu Glu Cys Arg  
 85 90 95

Val Lys Gly Pro Gly Ile Ser Lys Phe Val Gln Lys Val Asn Glu Ile  
 100 105 110

Gly Ile Tyr Leu Thr Asp Cys Met Glu Arg Ala Arg Glu Val Ile Pro  
 115 120 125

Arg Ser Gln His Gln Glu Thr Pro Val Tyr Leu Gly Ala Thr Ala Gly  
 130 135 140

Met Arg Leu Leu Arg Met Glu Ser Glu Glu Leu Ala Asp Arg Val Leu  
 145 150 155 160

Asp Val Val Glu Arg Ser Leu Ser Asn Tyr Pro Phe Asp Phe Gln Gly  
 165 170 175

Ala Arg Ile Ile Thr Gly Gln Glu Glu Gly Ala Tyr Gly Trp Ile Thr  
 180 185 190

Ile Asn Tyr Leu Leu Gly Lys Phe Ser Gln Lys Thr Arg Trp Phe Ser  
 195 200 205

Ile Val Pro Tyr Glu Thr Asn Asn Gln Glu Thr Phe Gly Ala Leu Asp  
 210 215 220

Leu Gly Gly Ala Ser Thr Gln Val Thr Phe Val Pro Gln Asn Gln Thr  
 225 230 235 240

Ile Glu Ser Pro Asp Asn Ala Leu Gln Phe Arg Leu Tyr Gly Lys Asp  
 245 250 255

Tyr Asn Val Tyr Thr His Ser Phe Leu Cys Tyr Gly Lys Asp Gln Ala  
 260 265 270

Leu Trp Gln Lys Leu Ala Lys Asp Ile Gln Val Ala Ser Asn Glu Ile  
 275 280 285

Leu Arg Asp Pro Cys Phe His Pro Gly Tyr Lys Lys Val Val Asn Val  
 290 295 300

Ser Asp Leu Tyr Lys Thr Pro Cys Thr Lys Arg Phe Glu Met Thr Leu  
 305 310 315 320

Pro Phe Gln Gln Phe Glu Ile Gln Gly Ile Gly Asn Tyr Gln Gln Cys  
 325 330 335

His Gln Ser Ile Leu Glu Leu Phe Asn Thr Ser Tyr Cys Pro Tyr Ser  
 340 345 350

Gln Cys Ala Phe Asn Gly Ile Phe Leu Pro Pro Leu Gln Gly Asp Phe  
 355 360 365

Gly Ala Phe Ser Ala Phe Tyr Phe Val Met Lys Phe Leu Asn Leu Thr  
 370 375 380

Ser Glu Lys Val Ser Gln Glu Lys Val Thr Glu Met Met Lys Lys Phe  
 385 390 395 400

Cys Ala Gln Pro Trp Glu Glu Ile Lys Thr Ser Tyr Ala Gly Val Lys  
 405 410 415

Glu Lys Tyr Leu Ser Glu Tyr Cys Phe Ser Gly Thr Tyr Ile Leu Ser  
 420 425 430

Leu Leu Leu Gln Gly Tyr His Phe Thr Ala Asp Ser Trp Glu His Ile  
 435 440 445

His Phe Ile Gly Lys Ile Gln Gly Ser Asp Ala Gly Trp Thr Leu Gly  
 450 455 460

Tyr Met Leu Asn Leu Thr Asn Met Ile Pro Ala Glu Gln Pro Leu Ser  
 465 470 475 480

Thr Pro Leu Ser His Ser Thr  
 485

<210> 27

<211> 464

<212> PRT

<213> Artificial Sequence

<220>

<223> Description of Artificial Sequence: Fusion  
 construct of human CD39

<400> 27

Met Ala Leu Trp Ile Asp Arg Met Gln Leu Leu Ser Cys Ile Ala Leu  
 1 5 10 15

Ser Leu Ala Leu Val Thr Asn Ser Ala Thr Gln Asn Lys Ala Leu Pro  
 20 25 30

Glu Asn Val Lys Tyr Gly Ile Val Leu Asp Ala Gly Ser Ser His Thr  
 35 40 45

Ser Leu Tyr Ile Tyr Lys Trp Pro Ala Glu Lys Glu Asn Asp Thr Gly  
 50 55 60

Val Val His Gln Val Glu Glu Cys Arg Val Lys Gly Pro Gly Ile Ser  
 65 70 75 80

Lys Phe Val Gln Lys Val Asn Glu Ile Gly Ile Tyr Leu Thr Asp Cys  
 85 90 95

Met Glu Arg Ala Arg Glu Val Ile Pro Arg Ser Gln His Gln Glu Thr  
 100 105 110

Pro Val Tyr Leu Gly Ala Thr Ala Gly Met Arg Leu Leu Arg Met Glu  
 115 120 125

Ser Glu Glu Leu Ala Asp Arg Val Leu Asp Val Val Glu Arg Ser Leu  
 130 135 140

Ser Asn Tyr Pro Phe Asp Phe Gln Gly Ala Arg Ile Ile Thr Gly Gln  
 145 150 155 160

Glu Glu Gly Ala Tyr Gly Trp Ile Thr Ile Asn Tyr Leu Leu Gly Lys  
 165 170 175

Phe Ser Gln Lys Thr Arg Trp Phe Ser Ile Val Pro Tyr Glu Thr Asn  
 180 185 190  
 Asn Gln Glu Thr Phe Gly Ala Leu Asp Leu Gly Gly Ala Ser Thr Gln  
 195 200 205  
 Val Thr Phe Val Pro Gln Asn Gln Thr Ile Glu Ser Pro Asp Asn Ala  
 210 215 220  
 Leu Gln Phe Arg Leu Tyr Gly Lys Asp Tyr Asn Val Tyr Thr His Ser  
 225 230 235 240  
 Phe Leu Cys Tyr Gly Lys Asp Gln Ala Leu Trp Gln Lys Leu Ala Lys  
 245 250 255  
 Asp Ile Gln Val Ala Ser Asn Glu Ile Leu Arg Asp Pro Cys Phe His  
 260 265 270  
 Pro Gly Tyr Lys Lys Val Val Asn Val Ser Asp Leu Tyr Lys Thr Pro  
 275 280 285  
 Cys Thr Lys Arg Phe Glu Met Thr Leu Pro Phe Gln Gln Phe Glu Ile  
 290 295 300  
 Gln Gly Ile Gly Asn Tyr Gln Gln Cys His Gln Ser Ile Leu Glu Leu  
 305 310 315 320  
 Phe Asn Thr Ser Tyr Cys Pro Tyr Ser Gln Cys Ala Phe Asn Gly Ile  
 325 330 335  
 Phe Leu Pro Pro Leu Gln Gly Asp Phe Gly Ala Phe Ser Ala Phe Tyr  
 340 345 350  
 Phe Val Met Lys Phe Leu Asn Leu Thr Ser Glu Lys Val Ser Gln Glu  
 355 360 365  
 Lys Val Thr Glu Met Met Lys Lys Phe Cys Ala Gln Pro Trp Glu Glu  
 370 375 380  
 Ile Lys Thr Ser Tyr Ala Gly Val Lys Glu Lys Tyr Leu Ser Glu Tyr  
 385 390 395 400  
 Cys Phe Ser Gly Thr Tyr Ile Leu Ser Leu Leu Leu Gln Gly Tyr His  
 405 410 415  
 Phe Thr Ala Asp Ser Trp Glu His Ile His Phe Ile Gly Lys Ile Gln  
 420 425 430  
 Gly Ser Asp Ala Gly Trp Thr Leu Gly Tyr Met Leu Asn Leu Thr Asn  
 435 440 445  
 Met Ile Pro Ala Glu Gln Pro Leu Ser Thr Pro Leu Ser His Ser Thr  
 450 455 460



<210> 28  
 <211> 474  
 <212> PRT  
 <213> Artificial Sequence

<220>  
 <223> Description of Artificial Sequence: Fusion  
 construct of human CD39

<400> 28  
 Met Ala Leu Trp Ile Asp Arg Met Gln Leu Leu Ser Cys Ile Ala Leu  
           1                          5                          10                          15  
  
 Ser Leu Ala Leu Val Thr Asn Ser Ala Ser Thr Lys Lys Thr Gln Leu  
                           20                          25                          30  
  
 Thr Ser Ser Thr Gln Asn Lys Ala Leu Pro Glu Asn Val Lys Tyr Gly  
                           35                          40                          45  
  
 Ile Val Leu Asp Ala Gly Ser Ser His Thr Ser Leu Tyr Ile Tyr Lys  
           50                          55                          60  
  
 Trp Pro Ala Glu Lys Glu Asn Asp Thr Gly Val Val His Gln Val Glu  
           65                          70                          75                          80  
  
 Glu Cys Arg Val Lys Gly Pro Gly Ile Ser Lys Phe Val Gln Lys Val  
                           85                          90                          95  
  
 Asn Glu Ile Gly Ile Tyr Leu Thr Asp Cys Met Glu Arg Ala Arg Glu  
                           100                          105                          110  
  
 Val Ile Pro Arg Ser Gln His Gln Glu Thr Pro Val Tyr Leu Gly Ala  
           115                          120                          125  
  
 Thr Ala Gly Met Arg Leu Leu Arg Met Glu Ser Glu Glu Leu Ala Asp  
           130                          135                          140  
  
 Arg Val Leu Asp Val Val Glu Arg Ser Leu Ser Asn Tyr Pro Phe Asp  
           145                          150                          155                          160  
  
 Phe Gln Gly Ala Arg Ile Ile Thr Gly Gln Glu Glu Gly Ala Tyr Gly  
                           165                          170                          175  
  
 Trp Ile Thr Ile Asn Tyr Leu Leu Gly Lys Phe Ser Gln Lys Thr Arg  
           180                          185                          190  
  
 Trp Phe Ser Ile Val Pro Tyr Glu Thr Asn Asn Gln Glu Thr Phe Gly  
           195                          200                          205  
  
 Ala Leu Asp Leu Gly Gly Ala Ser Thr Gln Val Thr Phe Val Pro Gln  
           210                          215                          220  
  
 Asn Gln Thr Ile Glu Ser Pro Asp Asn Ala Leu Gln Phe Arg Leu Tyr  
           225                          230                          235                          240  
  
 Gly Lys Asp Tyr Asn Val Tyr Thr His Ser Phe Leu Cys Tyr Gly Lys  
                           245                          250                          255

Asp Gln Ala Leu Trp Gln Lys Leu Ala Lys Asp Ile Gln Val Ala Ser  
 260 265 270

Asn Glu Ile Leu Arg Asp Pro Cys Phe His Pro Gly Tyr Lys Lys Val  
 275 280 285

Val Asn Val Ser Asp Leu Tyr Lys Thr Pro Cys Thr Lys Arg Phe Glu  
 290 295 300

Met Thr Leu Pro Phe Gln Gln Phe Glu Ile Gln Gly Ile Gly Asn Tyr  
 305 310 315 320

Gln Gln Cys His Gln Ser Ile Leu Glu Leu Phe Asn Thr Ser Tyr Cys  
 325 330 335

Pro Tyr Ser Gln Cys Ala Phe Asn Gly Ile Phe Leu Pro Pro Leu Gln  
 340 345 350

Gly Asp Phe Gly Ala Phe Ser Ala Phe Tyr Phe Val Met Lys Phe Leu  
 355 360 365

Asn Leu Thr Ser Glu Lys Val Ser Gln Glu Lys Val Thr Glu Met Met  
 370 375 380

Lys Lys Phe Cys Ala Gln Pro Trp Glu Glu Ile Lys Thr Ser Tyr Ala  
 385 390 395 400

Gly Val Lys Glu Lys Tyr Leu Ser Glu Tyr Cys Phe Ser Gly Thr Tyr  
 405 410 415

Ile Leu Ser Leu Leu Leu Gln Gly Tyr His Phe Thr Ala Asp Ser Trp  
 420 425 430

Glu His Ile His Phe Ile Gly Lys Ile Gln Gly Ser Asp Ala Gly Trp  
 435 440 445

Thr Leu Gly Tyr Met Leu Asn Leu Thr Asn Met Ile Pro Ala Glu Gln  
 450 455 460

Pro Leu Ser Thr Pro Leu Ser His Ser Thr  
 465 470

<210> 29  
 <211> 473  
 <212> PRT  
 <213> Artificial Sequence

<220>  
 <223> Description of Artificial Sequence: Fusion  
 construct of human CD39

<400> 29  
 Met Ala Leu Trp Ile Asp Arg Met Gln Leu Leu Ser Cys Ile Ala Leu  
 1 5 10 15

Ser Leu Ala Leu Val Thr Asn Ser Ser Thr Lys Lys Thr Gln Leu Thr  
 20 25 30

Ser Ser Thr Gln Asn Lys Ala Leu Pro Glu Asn Val Lys Tyr Gly Ile  
 35 40 45

Val Leu Asp Ala Gly Ser Ser His Thr Ser Leu Tyr Ile Tyr Lys Trp  
 50 55 60

Pro Ala Glu Lys Glu Asn Asp Thr Gly Val Val His Gln Val Glu Glu  
 65 70 75 80

Cys Arg Val Lys Gly Pro Gly Ile Ser Lys Phe Val Gln Lys Val Asn  
 85 90 95

Glu Ile Gly Ile Tyr Leu Thr Asp Cys Met Glu Arg Ala Arg Glu Val  
 100 105 110

Ile Pro Arg Ser Gln His Gln Glu Thr Pro Val Tyr Leu Gly Ala Thr  
 115 120 125

Ala Gly Met Arg Leu Leu Arg Met Glu Ser Glu Glu Leu Ala Asp Arg  
 130 135 140

Val Leu Asp Val Val Glu Arg Ser Leu Ser Asn Tyr Pro Phe Asp Phe  
 145 150 155 160

Gln Gly Ala Arg Ile Ile Thr Gly Gln Glu Gly Ala Tyr Gly Trp  
 165 170 175

Ile Thr Ile Asn Tyr Leu Leu Gly Lys Phe Ser Gln Lys Thr Arg Trp  
 180 185 190

Phe Ser Ile Val Pro Tyr Glu Thr Asn Asn Gln Glu Thr Phe Gly Ala  
 195 200 205

Leu Asp Leu Gly Gly Ala Ser Thr Gln Val Thr Phe Val Pro Gln Asn  
 210 215 220

Gln Thr Ile Glu Ser Pro Asp Asn Ala Leu Gln Phe Arg Leu Tyr Gly  
 225 230 235 240

Lys Asp Tyr Asn Val Tyr Thr His Ser Phe Leu Cys Tyr Gly Lys Asp  
 245 250 255

Gln Ala Leu Trp Gln Lys Leu Ala Lys Asp Ile Gln Val Ala Ser Asn  
 260 265 270

Glu Ile Leu Arg Asp Pro Cys Phe His Pro Gly Tyr Lys Lys Val Val  
 275 280 285

Asn Val Ser Asp Leu Tyr Lys Thr Pro Cys Thr Lys Arg Phe Glu Met  
 290 295 300

Thr Leu Pro Phe Gln Gln Phe Glu Ile Gln Gly Ile Gly Asn Tyr Gln  
 305 310 315 320

Gln Cys His Gln Ser Ile Leu Glu Leu Phe Asn Thr Ser Tyr Cys Pro  
 325 330 335

Tyr Ser Gln Cys Ala Phe Asn Gly Ile Phe Leu Pro Pro Leu Gln Gly  
 340 345 350

Asp Phe Gly Ala Phe Ser Ala Phe Tyr Phe Val Met Lys Phe Leu Asn  
 355 360 365

Leu Thr Ser Glu Lys Val Ser Gln Glu Lys Val Thr Glu Met Met Lys  
 370 375 380

Lys Phe Cys Ala Gln Pro Trp Glu Glu Ile Lys Thr Ser Tyr Ala Gly  
 385 390 395 400

Val Lys Glu Lys Tyr Leu Ser Glu Tyr Cys Phe Ser Gly Thr Tyr Ile  
 405 410 415

Leu Ser Leu Leu Leu Gln Gly Tyr His Phe Thr Ala Asp Ser Trp Glu  
 420 425 430

His Ile His Phe Ile Gly Lys Ile Gln Gly Ser Asp Ala Gly Trp Thr  
 435 440 445

Leu Gly Tyr Met Leu Asn Leu Thr Asn Met Ile Pro Ala Glu Gln Pro  
 450 455 460

Leu Ser Thr Pro Leu Ser His Ser Thr  
 465 470

<210> 30  
 <211> 463  
 <212> PRT  
 <213> Artificial Sequence

<220>  
 <223> Description of Artificial Sequence: Fusion  
 construct of human CD39

<400> 30  
 Met Glu Thr Asp Thr Leu Leu Leu Trp Val Leu Leu Leu Trp Val Pro  
 1 5 10 15

Gly Ser Thr Gly Ala Pro Thr Ser Thr Gln Asn Lys Ala Leu Pro Glu  
 20 25 30

Asn Val Lys Tyr Gly Ile Val Leu Asp Ala Gly Ser Ser His Thr Ser  
 35 40 45

Leu Tyr Ile Tyr Lys Trp Pro Ala Glu Lys Glu Asn Asp Thr Gly Val  
 50 55 60

Val His Gln Val Glu Glu Cys Arg Val Lys Gly Pro Gly Ile Ser Lys  
 65 70 75 80

Phe Val Gln Lys Val Asn Glu Ile Gly Ile Tyr Leu Thr Asp Cys Met  
 85 90 95

Glu Arg Ala Arg Glu Val Ile Pro Arg Ser Gln His Gln Glu Thr Pro  
 100 105 110  
 Val Tyr Leu Gly Ala Thr Ala Gly Met Arg Leu Leu Arg Met Glu Ser  
 115 120 125  
 Glu Glu Leu Ala Asp Arg Val Leu Asp Val Val Glu Arg Ser Leu Ser  
 130 135 140  
 Asn Tyr Pro Phe Asp Phe Gln Gly Ala Arg Ile Ile Thr Gly Gln Glu  
 145 150 155 160  
 Glu Gly Ala Tyr Gly Trp Ile Thr Ile Asn Tyr Leu Leu Gly Lys Phe  
 165 170 175  
 Ser Gln Lys Thr Arg Trp Phe Ser Ile Val Pro Tyr Glu Thr Asn Asn  
 180 185 190  
 Gln Glu Thr Phe Gly Ala Leu Asp Leu Gly Gly Ala Ser Thr Gln Val  
 195 200 205  
 Thr Phe Val Pro Gln Asn Gln Thr Ile Glu Ser Pro Asp Asn Ala Leu  
 210 215 220  
 Gln Phe Arg Leu Tyr Gly Lys Asp Tyr Asn Val Tyr Thr His Ser Phe  
 225 230 235 240  
 Leu Cys Tyr Gly Lys Asp Gln Ala Leu Trp Gln Lys Leu Ala Lys Asp  
 245 250 255  
 Ile Gln Val Ala Ser Asn Glu Ile Leu Arg Asp Pro Cys Phe His Pro  
 260 265 270  
 Gly Tyr Lys Lys Val Val Asn Val Ser Asp Leu Tyr Lys Thr Pro Cys  
 275 280 285  
 Thr Lys Arg Phe Glu Met Thr Leu Pro Phe Gln Gln Phe Glu Ile Gln  
 290 295 300  
 Gly Ile Gly Asn Tyr Gln Gln Cys His Gln Ser Ile Leu Glu Leu Phe  
 305 310 315 320  
 Asn Thr Ser Tyr Cys Pro Tyr Ser Gln Cys Ala Phe Asn Gly Ile Phe  
 325 330 335  
 Leu Pro Pro Leu Gln Gly Asp Phe Gly Ala Phe Ser Ala Phe Tyr Phe  
 340 345 350  
 Val Met Lys Phe Leu Asn Leu Thr Ser Glu Lys Val Ser Gln Glu Lys  
 355 360 365  
 Val Thr Glu Met Met Lys Lys Phe Cys Ala Gln Pro Trp Glu Glu Ile  
 370 375 380  
 Lys Thr Ser Tyr Ala Gly Val Lys Glu Lys Tyr Leu Ser Glu Tyr Cys  
 385 390 395 400

Phe Ser Gly Thr Tyr Ile Leu Ser Leu Leu Leu Gln Gly Tyr His Phe  
 405 410 415

Thr Ala Asp Ser Trp Glu His Ile His Phe Ile Gly Lys Ile Gln Gly  
 420 425 430

Ser Asp Ala Gly Trp Thr Leu Gly Tyr Met Leu Asn Leu Thr Asn Met  
 435 440 445

Ile Pro Ala Glu Gln Pro Leu Ser Thr Pro Leu Ser His Ser Thr  
 450 455 460

<210> 31

<211> 58

<212> PRT

<213> Homo sapiens

<400> 31

Met Ala Thr Ser Trp Gly Thr Val Phe Phe Met Leu Val Val Ser Cys  
 1 5 10 15

Val Cys Ser Ala Val Ser His Arg Asn Gln Gln Thr Trp Phe Glu Gly  
 20 25 30

Ile Phe Leu Ser Ser Met Cys Pro Ile Asn Val Ser Ala Ser Thr Leu  
 35 40 45

Tyr Gly Ile Met Phe Asp Ala Gly Ser Thr  
 50 55

INTERNATIONAL SEARCH REPORT

International application No.  
PCT/US99/22955

**A. CLASSIFICATION OF SUBJECT MATTER**  
 IPC(6) : C07H 21/02, 21/04; C07K 1/00; C12K 1/00  
 US CL : 530/350, 402, 403; 435/FOR 136; 536/23.1, 23.5  
 According to International Patent Classification (IPC) or to both national classification and IPC

**B. FIELDS SEARCHED**  
 Minimum documentation searched (classification system followed by classification symbols)  
 U.S. : 530/350, 402, 403; 435/FOR 136; 536/23 1, 23.5

Documentation searched other than minimum documentation to the extent that such documents are included in the fields searched

Electronic data base consulted during the international search (name of data base and, where practicable, search terms used)  
 Medline, WEST

**C. DOCUMENTS CONSIDERED TO BE RELEVANT**

Category*	Citation of document, with indication, where appropriate, of the relevant passages	Relevant to claim No.
Y	US 5,506,126 A (SEED et al.) 09 April 1996, see entire document.	1-15, 30, and 31
P, Y	US 5,798,241 A (BEAUDOIN et al) 25 August 1998, see entire document.	1-15, 30, and 31
Y	WO 96/32471 A3 (UNIVERSITE DE SHERBROOKE) 17 October 1996, see entire document.	1-15, 30, and 31
Y	GAYLE 3rd et al. Inhibition of platelet function by recombinant soluble ecto-ADPase/CD39. Journal of Clinical Investigation. 01 May 1998, Vol.101. No. 9, pp.1851-9, see entire document.	1-15, 30, and 31

Further documents are listed in the continuation of Box C.  See patent family annex.

* Special categories of cited documents.	*T* later document published after the international filing date or priority date and not in conflict with the application but cited to understand the principle or theory underlying the invention
*A* document defining the general state of the art which is not considered to be of particular relevance	*X* document of particular relevance; the claimed invention cannot be considered novel or cannot be considered to involve an inventive step when the document is taken alone
*E* earlier document published on or after the international filing date	*Y* document of particular relevance; the claimed invention cannot be considered to involve an inventive step when the document is combined with one or more other such documents, such combination being obvious to a person skilled in the art
*L* document which may throw doubts on priority claim(s) or which is cited to establish the publication date of another citation or other special reason (as specified)	*A* document member of the same patent family
*O* document referring to an oral disclosure, use, exhibition or other means	
*P* document published prior to the international filing date but later than the priority date claimed	

Date of the actual completion of the international search 04 JANUARY 2000	Date of mailing of the international search report 17 FEB 2000
Name and mailing address of the ISA/US Commissioner of Patents and Trademarks Box PCT Washington, D.C. 20231 Facsimile No. (703) 305-3230	Authorized officer JEFFREY STUCKER Telephone No. (703) 308-0196

INTERNATIONAL SEARCH REPORT

International application No.  
PCT/US99/22955

C (Continuation). DOCUMENTS CONSIDERED TO BE RELEVANT		
Category*	Citation of document, with indication, where appropriate, of the relevant passages	Relevant to claim No.
Y	WANG et al. The transmembrane domains of ectoapyrase (CD39) affect its enzymatic activity and quaternary structure Journal of Biological Chemistry, 18 September 1998, Vol. 273, No. 38, pp. 24814-21. ABSTRACT ONLY, see entire document.	1-15, 30, and 31



INTERNATIONAL SEARCH REPORT

International application No.  
PCT/US99/22955

Box I Observations where certain claims were found unsearchable (Continuation of item 1 of first sheet)

This international report has not been established in respect of certain claims under Article 17(2)(a) for the following reasons:

1.  Claims Nos.:  
because they relate to subject matter not required to be searched by this Authority, namely:
  
2.  Claims Nos.:  
because they relate to parts of the international application that do not comply with the prescribed requirements to such an extent that no meaningful international search can be carried out, specifically:
  
3.  Claims Nos.:  
because they are dependent claims and are not drafted in accordance with the second and third sentences of Rule 6.4(a).

Box II Observations where unity of invention is lacking (Continuation of item 2 of first sheet)

This International Searching Authority found multiple inventions in this international application, as follows:

Please See Extra Sheet.

1.  As all required additional search fees were timely paid by the applicant, this international search report covers all searchable claims.
2.  As all searchable claims could be searched without effort justifying an additional fee, this Authority did not invite payment of any additional fee.
3.  As only some of the required additional search fees were timely paid by the applicant, this international search report covers only those claims for which fees were paid specifically claims Nos.:  
1-15
4.  No required additional search fees were timely paid by the applicant. Consequently, this international search report is restricted to the invention first mentioned in the claims; it is covered by claims Nos.:

Remark on Protest

- The additional search fees were accompanied by the applicant's protest.  
 No protest accompanied the payment of additional search fees.

**INTERNATIONAL SEARCH REPORT**

International application No.

PCT/US99/22955

**BOX II. OBSERVATIONS WHERE UNITY OF INVENTION WAS LACKING**

This ISA found multiple inventions as follows:

Group I, claims 1-8, 30, 31, drawn to a peptide.

Group II, claims 9-15, drawn to DNA encoding a peptide.

Group III, claims 16-29, drawn to a vector, transformed cell, and a method of use.

Group IV, claims 32-34, drawn to a pharmaceutical composition.

Group V, claim 35, drawn to a method of treatment.

The inventions listed as Groups I-V do not relate to a single inventive concept under PCT Rule 13.1 because, under PCT Rule 13.2, they lack the same or corresponding special technical features for the following reasons: The instant claims lack a special technical feature because the invention, soluble CD39, is known in the art. See for example Gayle 3rd et al., (Inhibition of platelet function by recombinant soluble ecto-ADPase/CD39. JOURNAL OF CLINICAL INVESTIGATION. Vol.101. No. 9(1 May 1998) pp.1851-9, ABSTRACT ONLY). Therefore, the claims do not have a special technical feature. Further, applicant claims multiple products and methods in the instant invention. Thus, the instant invention can not be said to have unity of invention.

**This Page is Inserted by IFW Indexing and Scanning  
Operations and is not part of the Official Record**

**BEST AVAILABLE IMAGES**

Defective images within this document are accurate representations of the original documents submitted by the applicant.

Defects in the images include but are not limited to the items checked:

- BLACK BORDERS**
- IMAGE CUT OFF AT TOP, BOTTOM OR SIDES**
- FADED TEXT OR DRAWING**
- BLURRED OR ILLEGIBLE TEXT OR DRAWING**
- SKEWED/SLANTED IMAGES**
- COLOR OR BLACK AND WHITE PHOTOGRAPHS**
- GRAY SCALE DOCUMENTS**
- LINES OR MARKS ON ORIGINAL DOCUMENT**
- REFERENCE(S) OR EXHIBIT(S) SUBMITTED ARE POOR QUALITY**
- OTHER:** \_\_\_\_\_

**IMAGES ARE BEST AVAILABLE COPY.**

**As rescanning these documents will not correct the image problems checked, please do not report these problems to the IFW Image Problem Mailbox.**